



4800 Ashford Dunwoody Road
Dunwoody, Georgia 30338
dunwoodyga.gov | 678.382.6700

INVITATION TO BID

ITB 24-01

2024 MAINTENANCE REPAIRS SHALLOWFORD ANNEX BUILDING



Invitation to Bid

ITB 24-01

The City of Dunwoody is soliciting competitive sealed bids from qualified contractors for the 2024 Maintenance Repairs Shallowford Annex Building for the Department of Parks and Recreation.

Bids should be typed or submitted in ink and returned in a sealed container marked on the outside with the ITB number and Company Name. Bids will be received until 2:00 P.M. local time on **Friday January 26, 2024**, at the City of Dunwoody, 4800 Ashford Dunwoody Road Dunwoody, GA 30338. Any bid received after this date and time will not be accepted. Bids will be publicly opened and read at 2:05 P.M. Apparent bid results will be available the following business day on our website www.dunwoodyga.gov.

Bidders are expected to be familiar with the Bid Documents and MUST familiarize themselves with the scope of work. Provide the City with any questions regarding the Bid Documents by the deadline for questions to be submitted.

Questions regarding bids should be directed to John Gates, Purchasing Manager, at purchasing@dunwoodyga.gov no later than **Wednesday January 10, 2024**. Bids are legal and binding upon the bidder when submitted. All bids should be submitted in duplicate.

The written bid documents supersede any verbal or written prior communications between the parties.

Award will be made to the supplier submitting the lowest responsive and responsible bid. The City reserves the right to reject any or all bids to waive technicalities and to make an award deemed in its best interest. Bids may be split or awarded in entirety. The City reserves the option to negotiate terms, conditions and pricing with the lowest responsive, responsible bidder(s) at its discretion.

All companies submitting a bid will be notified in writing of award.

We look forward to your bid and appreciate your interest in the City of Dunwoody.

John Gates
Purchasing Manager

SCOPE OF WORK

The **2024 Maintenance Repairs Shallowford Annex Building** scope: The contractor shall furnish all materials, equipment, and labor to complete the required construction repairs as described in its entirety to the specifications as directed and the terms of this contract including all incidentals as directed by the City of Dunwoody Director of Parks and Recreation or his representative.

General Notes:

1. Work is anticipated to begin early in the 2nd quarter of 2024 and be completed within 90 calendar days of the official Notice to Proceed. The contractor and the City will conduct one (1) pre-construction meeting shortly after award of the contract. The contractor and the City will discuss the terms of the contract as well as the schedule for the Work. Following the Pre-Con, the schedule terms will be documented in the Minutes and will be the Work Plan by which the contractor must complete the Work.
 - a. Identify Start Date
 - b. Identify Completion date: Not to Exceed 90 calendar days following NTP.
2. The contractor is responsible for calling for utility locations prior to the start of work. It shall be the contractor's responsibility to coordinate his work with any utility owner which may be in conflict with his work.
3. Any item which must be removed during the construction work and is not specifically called for shall be removed by the contractor. The cost shall be included in other unit price bid. No claims will be considered for extra compensation.
4. Upon the completion of the work, any excess items which might be left over from the construction-related work, shall be removed, and disposed of properly by the contractor within 24 hours. Under no circumstances will debris be allowed to remain in the roadway while under traffic. The cost for such removal and disposal of such items will be included in other unit price bid. No claims will be considered for extra compensation.
5. *Work Hours*- Working hours are limited to Monday through Friday, 7:30 AM to 8:30 PM unless prior approval is granted by the Department of Parks and Recreation. Saturday work may be allowed with prior approval. A 48-hour advance notice is required for any consideration of Saturday work.
6. Contractor shall have all vehicles marked with their company name.

7. The City of Dunwoody will not provide restroom facilities. The contractor shall arrange for a portable restroom facility at each geographical location for the duration of the time that crews are deployed to the area.
8. The Contractor shall perform project housekeeping/clean-up on a daily basis. A 24-hour contact must be provided to the City of Dunwoody for all issues as needed in regard to the project for any safety, signage, or other emergency as needed. In the event the Contractor fails to clean up within 24 hours of being notified, the City reserves the right to have the work performed by Others, and the Contractor will be back charged for the cost of the work.
9. The contractor shall obtain permission from any private property owner on whose property construction equipment may be parked. Failure to obtain permission from property owners may result in citations.
10. Proof of Commercial general liability insurance with coverage of not less than ONE MILLION DOLLARS (\$1,000,000.00) combined single limit per occurrence, and with contractual liability coverage for Contractor's covenants to and indemnification of the City under the Contract.
11. A Bid Bond is not required for this project.
12. The contractor shall be responsible for any damage to public or private property caused by the Work such as street signs, mailboxes, fences, curb damage, driveway damage, hardscaping damage, etc.
 - a. In the event the contractor (or subcontractors working for them) damage private or public property (including but not limited to sidewalks, curb and gutter, pavement, driveway aprons, etc.) in the course of performing the Work, the contractor shall be responsible for making restitution.
 - b. Contractor shall be responsible for communication with property owner(s) directly with regard to all property damage claims. Contractor shall copy City of Dunwoody on status of each claim until resolved.

END OF GENERAL NOTES

2024 MAINTENANCE REPAIRS CITY OF DUNWOODY - PARKS & RECREATION SHALLOWFORD ANNEX BUILDING 4470 N Shallowford Rd, Atlanta, GA 30338



CITY OF DUNWOODY OFFICIALS

GABE NEPS, PARKS OPERATION MANAGER
ERIC LINTON, CITY MANAGER
LYNN DEUTSCH, MAYOR

STRUCTURAL & WATERPROOFING CONSULTANT:

J. LLOYD ENGINEERING, LLC
JOSHUA R. LLOYD, PE
JLE PROJECT NO. 22608

MATERIALS ENGINEER:

SGS TEC SERVICES
BRIAN J. WOLFE, PE
Project No. 22131

DRAWING INDEX:

Sheet No.	DESCRIPTION
R0	COVER PAGE & INDEX
R1	EXTERIOR REPAIR PAY ITEMS, QUANTITIES & ALLOWANCE
R2	GENERAL NOTES
R3	GENERAL NOTES
R4	GENERAL NOTES & ABBREVIATIONS AND TYPICAL CALLOUTS
R5	PLAN VIEW
R6, R7, R8	WINDOW SPECIFICATION
R9	PLAN VIEW
R10	ELEVATIONS
R11	ELEVATIONS
R12	SECTIONS/DETAILS
R13	SECTIONS/DETAILS
R14	SECTIONS/DETAILS
R15	SECTIONS/DETAILS
R16	EXAMPLE DETAILS FOR FIXED WINDOWS
R17	MASONRY HELICAL PIN REPAIR SECTIONS & DETAILS

PROJECT LOCATION

DEKALB COUNTY

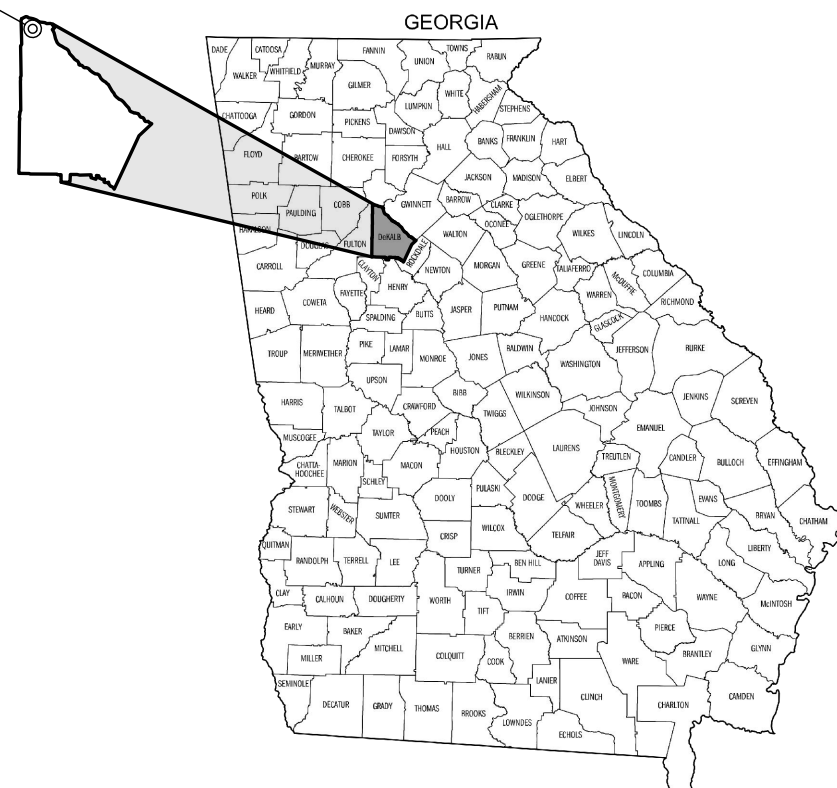

VICINITY MAP

PROJECT SITE

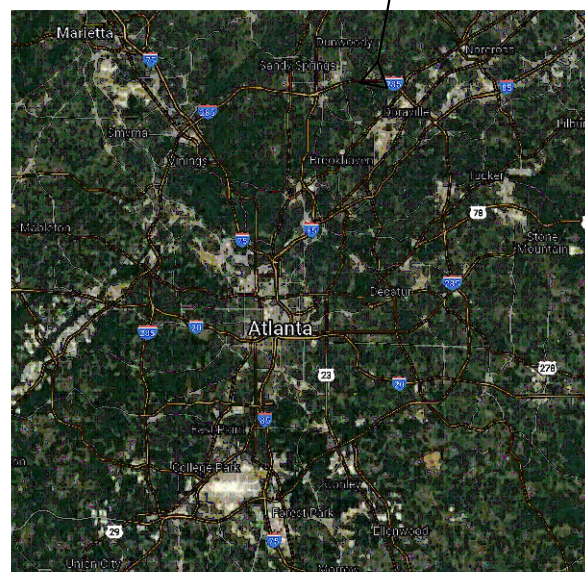

BUILDING EXTENTS

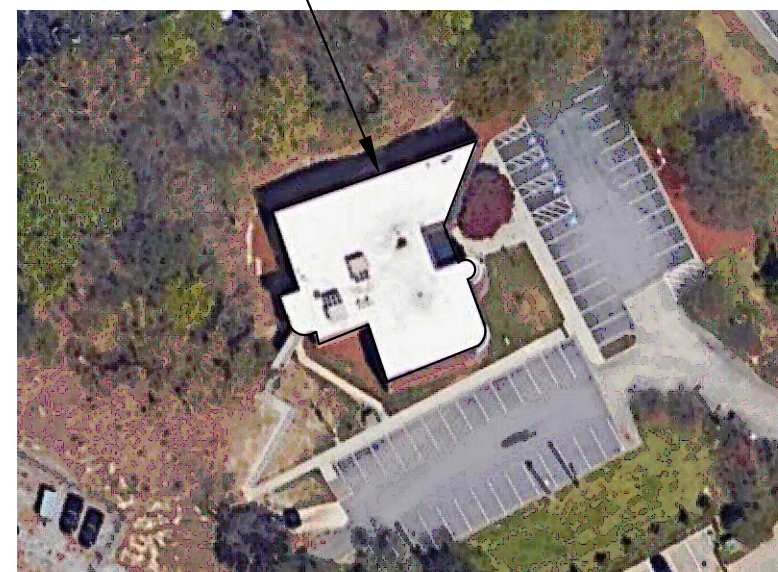

REVISIONS		
No.	DESCRIPTION	DATE
0	90% SET FOR BID	03-NOV-23

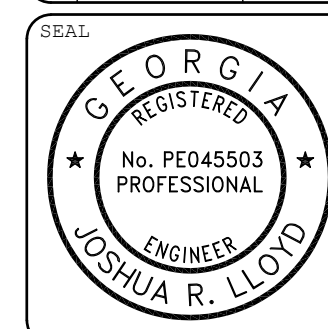

PROJECT: **SHALLOWFORD ANNEX MASONRY & WATERPROOFING RESTORATION**
4470 N Shallowford Rd, Atlanta, GA
CITY OF DUNWOODY PARKS DEPT.

SHEET DESCRIPTION:
CONDITION ASSESSMENT
OBSERVATIONS

PROJECT No.: SG522131
JLE22606
DRAWN BY: JRL
CHECK BY: JRL
DATE: 03-NOV-23

SHEET No.
RO



GENERAL REQUIREMENTS

PAY ITEM No.	PAY ITEM DESCRIPTION	UNIT	QUANTITY
0	PRICE FOR BID ACCESS REQUIREMENTS: LUMP SUM SHALL INCLUDE ALL RENTAL EQUIPMENT/APPARATUS FOR THE DURATION OF WORK, MAINTENANCE, REPAIR OF DAMAGED EXISTING ELEMENTS (I.E. WINDOWS NOT BEING REPLACED, MEP EQUIPMENT THAT WAS TO REMAIN, GROUNDS, ETC.) DUE TO CONTRACTOR ERROR, SAFETY REQUIREMENTS DURING USE, AND ANY SIGNANGE REQUIRED FOR ENTRANCE/EXIT EGRESS.	LS	LUMP

EXTERIOR REPAIR ITEMS

PAY ITEM No.	PAY ITEM DESCRIPTION	UNIT	QUANTITY
1	REMOVE AND REPLACE CONTRACTION JOINT MATERIALS	LF	233
2	REMOVE AND REPLACE WINDOW GLAZING/CAULKING	LS	LUMP
3	REMOVE BRICK ABOVE EXISTING GLASS BLOCK WALL, REPAIR WATERPROOFING, AND REPLACE BRICK VENEER TO MATCH		
3.1	REMOVE & REPLACE EXISTING BRICK FAÇADE ABOVE THE STRUCTURAL STEEL FRAME FOR WATERPROOFING REPAIRS	SF	750
3.2	REMOVE & REPLACE EXISTING DETERIORATED GYPSUM SHEATHING (ALLOWANCE, ACTUAL QUANTITY TO BE FIELD VARIFIED)	SF	325
3.3	WATERPROOF ALL SHEATHING SEAMS, ROUGH OPENINGS, AND WALL SHEATHING USING FLUID APPLIED AIR & WATERPROOF BARRIER & LIQUID FLASHING MEMBRANE	SF	750
3.4	REMOVE AND REPLACE FLASHING AT EXISTING TOP OF CMU WALL STRUCTURAL STEEL	LF	83
4	REMOVE EXISTING GLASS BLOCK WALL AND REPLACE w/ METAL STUD INTERIOR FRAMING AND BRICK VENEER TO MATCH		
4.1	REMOVE EXISTING GLASS BLOCK WALL, INSTALL SUPPLEMENTAL SHORING TO SUPPORT EXISTING STRUCTURAL STEEL WHILE REPAIRS ARE IN PROGRESS	SF	770
4.2	INSTALL 6" STUD WALL SYSTEM, ATTACHING STUD TRACKS TO TOP AND BOTTOM STRUCTURAL STEEL SUPPORTS, STUDS AT 12" O.C. (MAX), INCLUDING FRAMING AT ALL WINDOW OPENINGS	SF	770
4.3	INSTALL NEW DRYWALL ON INTERIOR, FINISH ALL SEAMS, SAND AND PAINT PER OWNER	SF	770
4.4	INSTALL NEW EXTERIOR WALL SHEATHING, FINISH ALL SEAMS w/ LIQUID APPLIED FLASHING MEMBRANE AND COAT SHEATHING w/ FLUID APPLIED AIR & WATERPROOF BARRIER	SF	770
4.5	INSTALL NEW WINDOWS, w/ ALL WINDOW GLAZING/SEALANTS AND WINDOW SUPPORTS PER MANUFACTURER. APPROXIMATE WINDOW SIZES ARE INCLUDED ON SHEETS R8 AND R9.	LS	LUMP
5	REPAIR PARAPET CAP FLASHING AT CURVED ROOFTOP SECTIONS	LF	34
6	REPOINTING BRICK MASONRY (ALLOWANCE QTY PROVIDED, TO BE RECORDED IN THE FIELD AND APPROVED)	LF	500
7	REPINNING LOOSE BRICK w/ HELICAL PINS (ALLWANCE, TO BE FIELD VERIFIED)	SF	50
8	CLEAN AND COAT ALL EXISTING STEEL COMPONENTS; LINTELS, RELIEF ANGLES, AND STRUCTURAL SUPPORTS THAT REMAIN IN PLACE	Allowance	\$ 6,000.00
9	REMOVE AND REPLACE WOOD ROT (ALLOWANCE PROVIDED, BILLED TO OWNER AT COST + LABOR x ____ [UNIT PROVIDED AT RIGHT])	Allowance	\$ 5,000.00
		Mark Unit	
10	COAT EXTERIOR OF BUILDING w/ BRICK COATING SUCH AS SIKA MasterSeal HB 400 (OR APPROVED EQUIVALENT, CONTRACTOR TO PROVIDE INFORMATION w/ BID)	SF	8640
11	REMOVE AND REPLACE GLAZING ON WINDOWS, INCLUDING SOUTH WALL WINDOWS, FRONT ENTRANCE WINDOWS/DOOR ASSEMBLY, AND NORTH WALL WINDOWS (CONTRACTOR VERIFY QUANTITY, LUMP SUM)	LS	LUMP

SGS **TEC SERVICES**
 Testing • Engineering • Consulting
 SGS NORTH AMERICA, INC (SGS TEC SERVICES)
 235 BUFORD DR, LAWRENCEVILLE, GA 30046
 770.995.8000 | Brian.Wolfe@SGS.COM

REVISIONS		
No.	DESCRIPTION	DATE
0	90% SET FOR BID	03-NOV-23

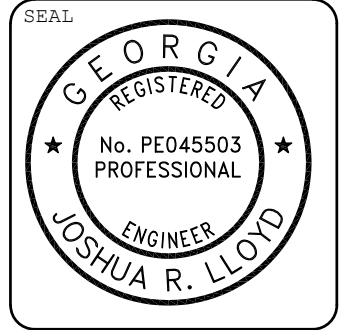

J. LLOYD
 ENGINEERING
 P.O. Box 169, Watkinsville, GA 30677
 404.518.6121 | JRL@Lloyd-Eng.com

PROJECT: **SHALLOWFORD ANNEX MASONRY & WATERPROOFING RESTORATION**
 4470 N Shallowford Rd, Atlanta, GA
 CITY OF DUNWOODY PARKS DEPT.
 SHEET DESCRIPTION: REPAIR PAY ITEMS, QUANTITIES & ALLOWANCE

PROJECT No.: SG522131
 JLE22606
 DRAWN BY: JRL
 CHECK BY: JRL
 DATE: 03-NOV-23

SHEET No.
R1

DESIGN STANDARDS

- INTERNATIONAL BUILDING CODE (IBC), 2018 EDITION w/ (2020) (2022) GEORGIA AMENDMENTS
- INTERNATIONAL EXISTING BUILDING CODE (IEBC), 2018 EDITION w/ (2021) GEORGIA AMENDMENTS

DESIGN LOADING

- GENERAL DESIGN
 - RISK CATEGORY..... II (EXISTING)
 - CONSTRUCTION TYPE III-A (EXISTING)
 - SNOW IMPORTANCE FACTOR $I_s = 1.00$
 - WIND IMPORTANCE FACTOR $I_w = 1.00$
 - SEISMIC IMPORTANCE FACTOR $I_e = 1.00$
- WIND DESIGN DATA
 - WIND DIRECTIONAL FACTOR $K_d = 0.85$
 - TOPOGRAPHIC EFFECT $K_{zt} = 1.0$
 - ULTIMATE DESIGN WIND SPEED $V = 105$ mph
 - GROUND ELEVATION 975 FT
 - EXPOSURE B
 - INTERNAL PRESSURE COEFFICIENT $GC_{pi} = \pm 0.18$
 - COMPONENTS & CLADDING
 - FLAT ROOF ZONE 1 16 PSF, -28.7 PSF
 - FLAT ROOF ZONE 1' 16 PSF, -16.5 PSF
 - FLAT ROOF ZONE 2 16 PSF, -37.9 PSF
 - FLAT ROOF ZONE 3 16 PSF, -51.7 PSF
 - WALL ZONE 4 18 PSF, -19.6 PSF
 - WALL ZONE 5 18 PSF, -24.1 PSF

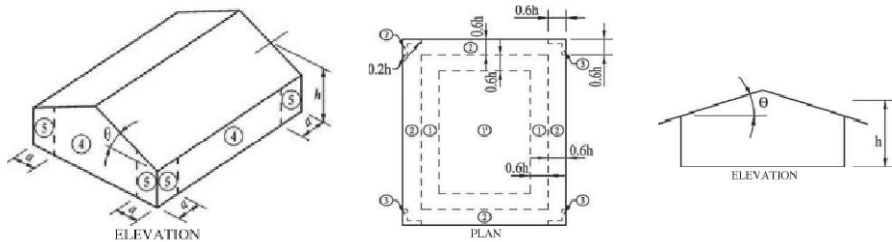

- EARTHQUAKE DESIGN DATA
 - 0.2 SEC SPECTRAL RESPONSE ACCEL $S_s = 0.196$
 $S_{ds} = 0.209$
 - 1.0 SEC SPECTRAL RESPONSE ACCEL $S_1 = 0.087$
 $S_{d1} = 0.140$
 - SOIL SITE CLASS D (ASSUMED)
 - 0.2 SECOND SITE AMPLIFICATION FACTOR $F_a = 1.6$
 - 1.0 SECOND SITE AMPLIFICATION FACTOR $F_v = 2.4$
 - SEISMIC DESIGN CATEGORY C
- SNOW LOADING 5 PSF
- DESIGN LOAD-BEARING VALUES
UNKNOWN AND NOT UTILIZED
- DESIGN LOADS
 - DEAD LOADS
 - BRICK VENEER 40 PSF
 - 6" STUD WALL ASSEMBLY 10 PSF
 - MISC/MECHANICAL 5 PSF
 - LIVE LOADS
 - FLOOR NOT APPLICABLE
 - ROOF 20 PSF

GENERAL CONSTRUCTION RESPONSIBILITIES

- THE EXTENT OF WORK REQUIRED BY DRAWINGS IS BASED UPON FIELD OBSERVATIONS AND INVESTIGATION AND IS SUBJECT TO CHANGE BASED UPON ACTUAL DEMOLITION AND SITE CONDITIONS.
- CONTRACTOR SHALL BE RESPONSIBLE FOR EXAMINING LIMITATIONS, MANUFACTURER SPECIFICATIONS, AND CONSTRUCTION DRAWINGS PRIOR TO SUBMITTING A BID FOR THIS PROJECT.
- THE CONTRACTOR SHALL SUPERVISE AND DIRECT THE WORK AND SHALL BE SOLELY RESPONSIBLE FOR ALL CONSTRUCTION MEANS, METHODS, PROCEDURES, TECHNIQUES, SEQUENCE, AND SAFETY. AS SUCH, ANY REQUIRED CONSTRUCTION ENGINEERING AND/OR DESIGN RESULTING FROM THESE SELECTIONS IS THE RESPONSIBILITY OF THE CONTRACTOR. THE ENGINEER DOES NOT HAVE CONTROL OR CHARGE OF, AND SHALL NOT BE RESPONSIBLE FOR:
 - CONSTRUCTION MEANS, METHODS, SEQUENCES, OR PROCEDURES
 - PRECAUTIONS AND PROGRAMS FOR SAFETY IN CONNECTION WITH WORK
 - THE ACTS OR OMISSIONS OF THE CONTRACTOR, SUBCONTRACTOR, OR ANY OTHER PERSONS, PERFORMING ANY OF THE WORK, OR FOR THE FAILURE OF ANY OF THEM TO CARRY OUT THE WORK IN ACCORDANCE WITH THE CONTRACT DOCUMENTS
- COORDINATE THE WORK TO PROTECT EXISTING UTILITIES PRESENT WITHIN THIS FRAMING. COORDINATE WITH THE APPROPRIATE AGENCIES AND VENDORS IN ADVANCE OF CONSTRUCTION. NOTIFY ENGINEER PRIOR TO CONSTRUCTION OF ANY UNRESOLVED CONFLICTS.
- REPAIRS ARE EXTERIOR AND SHOULD NOT BE NECESSARY TO LOAD FLOORS DURING CONSTRUCTION. IN THE EVENT THAT INTERIOR WORK IS NECESSARY, COORDINATE THE USE OF LIGHT MECHANIZED EQUIPMENT ON THE STRUCTURE WITH THE ENGINEER. DO NOT STOCKPILE SOIL, DEBRIS OR NEW CONSTRUCTION MATERIALS ON THE FRAMED SLAB AREA. COORDINATE PROVISIONS FOR TEMPORARY ACCESS TO UNITS WHERE WALKWAYS ARE UNDER CONSTRUCTION. ALL TEMPORARY SHORING AND BRACING DURING CONSTRUCTION IS THE RESPONSIBILITY OF THE CONTRACTOR.
- CONTRACTOR SHALL BE RESPONSIBLE FOR JOBSITE SAFETY, PROTECTION OF BUILDING OCCUPANTS, PEDESTRIANS, SHORING, AND TEMPORARY BRACING OF THE STRUCTURE DURING CONSTRUCTION. WHERE FULL DEPTH CONCRETE REPAIRS ARE REQUIRED, PROVIDE ENGINEER WITH SHORING AND/OR TEMPORARY BRACING DETAILS PRIOR TO COMMENCING WORK.
- CONTRACTOR SHALL BE RESPONSIBLE FOR THE REPAIR OF ALL WORK RELATED DAMAGE TO UTILITIES, BUILDING INTERIOR OR EXTERIOR COMPONENTS, LANDSCAPING, AND ADJACENT WINDOW SYSTEMS.

DRAWINGS AND EXISTING CONDITIONS

- THESE DRAWINGS HAVE BEEN PREPARED AND ISSUED STRICTLY FOR THE PURPOSE OF PROVIDING WATERPROOFING MAINTENANCE REPAIRS TO THE FACILITY BUILDING ENCLOSURE SYSTEM IN DUNWOODY, GA AND SHALL NOT BE USED FOR ANY OTHER PURPOSE WITHOUT WRITTEN CONSENT OF THE ENGINEER.
- CONTRACTOR SHALL BE RESPONSIBLE FOR FIELD VERIFICATION OF ALL DIMENSIONS, CONDITIONS, AND MEASUREMENTS. DO NOT SCALE DRAWINGS. NOTIFY ENGINEER IN WRITING WHERE DISCREPANCIES EXIST.
- WHERE EXPOSED CONDITIONS VARY FROM THOSE DETAILED WITHIN THIS CONSTRUCTION SET, CONTRACTOR SHALL NOTIFY ENGINEER TO RESOLVE ANY MODIFICATIONS PRIOR TO PROCEEDING WITH CONTINUED DEMOLITION OR INSTALLATION OF REPAIR MATERIALS.
- SHOULD MANUFACTURER RECOMMENDATIONS CONFLICT WITH THESE DRAWINGS, THE STRICTEST SHALL APPLY.
- A DETAIL SHOWN FOR ONE CONDITION SHALL APPLY FOR LIKE OR SIMILAR CONDITIONS THAT MAY NOT BE MARKED ON THE DRAWINGS, UNLESS NOTED OTHERWISE.
- SOME DETAILS OF EXISTING CONSTRUCTION, WHICH ARE NOT VISIBLE, HAVE BEEN ASSUMED AND ARE SUBJECT TO VERIFICATION. SIGNIFICANT DEVIATIONS FROM ASSUMED CONSTRUCTION MAY REQUIRE REVISION TO CERTAIN DETAILS. PLEASE CONTACT ENGINEER IN THIS CIRCUMSTANCE FOR CLARIFICATION.

SUBMITTALS, MOCK-UPS & INSPECTION

- WITHIN 10 BUSINESS DAYS OF RECEIPT OF OWNER'S NOTICE OF AWARD, SUBMITTALS SHALL BE SUBMITTED FOR ENGINEER REVIEW. ENGINEER SHALL HAVE 5 BUSINESS DAYS TO REVIEW AND APPROVE OR PROVIDE OFFICIAL RESPONSE. DATA SHALL INCLUDE THE FOLLOWING:
 - MATERIALS LIST OF ITEMS PROPOSED TO BE PROVIDED UNDER THIS SECTION.
 - MANUFACTURER'S PRODUCT DATA SHEET AND APPLICATION INSTRUCTIONS & WORK PROCEDURES FOR APPROVAL PRIOR TO MOBILIZATION TO PROJECT SITE.
 - CERTIFICATION FROM MATERIAL MANUFACTURER THAT ON SITE MECHANICS ARE TRAINED AND CURRENT APPROVED APPLICATORS OF THE PRODUCTS BEING USED.
 - SHOP DRAWINGS:
 - COLD-FORMED STEEL WALL FRAMING
 - WINDOWS (SEE SHEET R5 FOR SPECIFICATION OF WINDOWS)
- UPON APPROVAL OF PRODUCT SUBMITTALS, PURCHASE, AND DELIVERY OF PROJECT MATERIALS, PACKAGING SLIPS FROM THE PRODUCT MANUFACTURERS INDICATING THAT THE PRODUCTS DELIVERED TO THE SITE AND USED IN THE PROJECT ARE WITHIN THE MANUFACTURER'S PUBLISHED SHELF LIFE.

SGS
 Testing • Engineering • Consulting
TEC SERVICES
 SGS NORTH AMERICA, INC (SGS TEC SERVICES)
 235 BUFORD DR, LAWRENCEVILLE, GA 30046
 770.995.8000 | Brian.Wolfe@SGS.COM

REVISIONS		
No.	DESCRIPTION	DATE
0	90% SET FOR BID	03-NOV-23

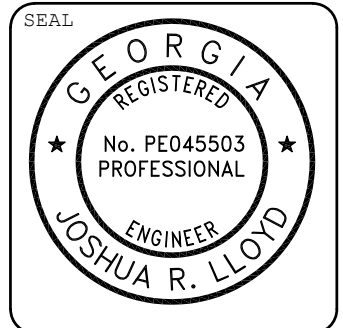

J. LLOYD
 ENGINEERING
 P.O. Box 169, Watkinsville, GA 30677
 404.518.6121 | JRL@Lloyd-Eng.com

PROJECT: **SHALLOWFORD ANNEX MASONRY & WATERPROOFING RESTORATION**
 4470 N Shallowford Rd, Atlanta, GA
 CITY OF DUNWOODY PARKS DEPT.
 SHEET DESCRIPTION: GENERAL NOTES

PROJECT No.: SG522131 / JLE22606
 DRAWN BY: JRL
 CHECK BY: JRL
 DATE: 03-NOV-23

SHEET No.
R2

SUBMITTALS, MOCK-UPS & INSPECTION (CONTINUED)

- 3. THE FOLLOWING SUBMITTALS SHALL BE SUBMITTED TO THE ENGINEER:
 - 3.1. BRICK VENEER
 - 3.2. MASONRY MORTAR
 - 3.3. MASONRY TIES
 - 3.4. WATERPROOFING: SEALANTS, FLASHING, WEEPS, ETC.
 - 3.5. EXTERIOR FACADE COATING
 - 3.6. STRUCTURAL STEEL CORROSION PRIMER/COATING
- 4. TESTING AND COMPLIANCE
 - 4.1. WATERPROOFING SYSTEM
 - 4.1.1. ENGINEER SHALL INSPECT MATERIALS MATCH APPROVED SUBMITTALS.
 - 4.1.2. ENGINEER SHALL INSPECT AND APPROVE IN WRITING ALL WATERPROOFING REPAIRS PRIOR TO PLACEMENT AND COMPLETION OF BRICK VENEER REPLACEMENT/PLACEMENT.
 - 4.1.3. CONTRACTOR SHALL CONTACT ENGINEER WITH A MINIMUM OF 3-DAYS HEADS UP FOR INSPECTION SERVICES.
 - 4.1.4. WATER TESTING SHALL BE PERFORMED IN THE PRESENCE OF THE ENGINEER TO VISUALLY ASSESS THAT THE WALL SYSTEM IS WATERTIGHT PRIOR TO VENEER (RE)PALCEMENT.
 - 4.2. MASONRY REPLACEMENT
 - 4.2.1. AFTER WATERPROOFING SYSTEM IS APPROVED, BRICK VENEER CAN BE INSTALLED.
 - 4.2.2. ENGINEER OR ENGINEER REPRESENTATIVE SHALL INSPECT MATERIALS MATCH APPROVED SUBMITTALS.
 - 4.2.3. PERIODIC/CONTINUOUS INSPECTION OF BRICK VENEER AND BRICK VENEER TIE INSTALLATION. IF AUTHORIZED, CONTRACTOR WILL MAY BE ALLOWED TO PHOTO DOCUMENT THE INSTALLATION OF VENEER TIES IN THE EVENT THAT ENGINEER INSPECTION CANNOT BE MAINTAINED FULL TIME.
 - 4.2.4. WHERE CONDITIONS WARRANT, ADDITIONAL TESTING SHALL BE PERFORMED AS DIRECTED BY THE ENGINEER.
 - 4.3. BRICK VENEER COATING
 - 4.3.1. CONTRACTOR SHALL PROVIDE A MINIMUM OF (1) MOCK-UP SAMPLE, INCLUDING SURFACE PREPARATION AND INSTALLATION OF COATING SYSTEM ON THE EXTERIOR OF THE BRICK FOR ENGINEER AND OWNER INSPECTION. THE SIZE OF THE MOCK-UP SHALL BE A MIN. OF 10'-0 BY 10'-0", HOWEVER; THIS SIZE CAN BE ADJUSTED WITH ENGINEERS WRITTEN APPROVAL
 - 4.3.2. VENEER SHALL BE PREPARED IN STRICT ACCORDANCE w/ MANUFACTURER REQUIREMENTS.
 - 4.3.3. AT COMPLETION OF ALL REPAIRS, WATER TESTING SHALL BE PERFORMED TO APPROVE REPAIRS ARE ADEQUATE AND MEET THE REQUIREMENTS OF THESE REPAIR DOCUMENTS.

MATERIALS

- 1. STRUCTURAL STEEL:
 - 1.1. PLATE, BAR, ANGLE, CHANNEL - ASTM A36
 - 1.2. HSS OR TUBE - ASTM A500 GR. B
- 2. WELDING:
 - 2.1. ELECTRODES - EXX70 (MIN 70KSI)
- 3. BRICK VENEER:
 - 3.1. SHALL COMPLY WITH ASTM C216.
 - 3.2. CONTRACTOR TO PROVIDE NEW BRICK THAT MATCHES SAME PROFILE, SHAPE AND SIZE TO EXISTING, HOWEVER; IF COLOR CANNOT BE A 100% MATCH, THIS WILL BE EXCEPTED AS A COATING IS BEING INSTALLED FOR A UNIFORM COLOR.
 - 3.3. PROVIDE A MINIMUM UNIT COMPRESSIVE STRENGTH OF 3350 PSI.
 - 3.4. ABSORPTION RATE SHALL BE LESS THAN 30G/30 SQ. IN PER MIN. IN ACCORDANCE WITH ASTM C67.

- 4. MASONRY MORTAR:
 - 4.1. COLOR SHALL MATCH EXISTING.
 - 4.2. MORTAR SHALL BY TYPE 'N', UNLESS FIELD MATCHING CONFIRMS OTHERWISE. CONTACT ENGINEER IMMEDIATELY IF TYPE 'N' CANNOT BE USED WITH EXISTING MORTAR.
 - 4.3. MATERIALS SHALL BE AS FOLLOWS:
 - a. PORTLAND CEMENT..... ASTM C150
 - b. MASONRY CEMENT ASTM C91
 - c. MORTAR PIGMENT ASTM C979
 - d. MORTAR AGGREGATE ASTM C144
 - e. WATER POTABLE
- 5. MASONRY VENEER TIES
 - 5.1. A MINIMUM OF A 1" AIR GAP SHALL BE PROVIDED, WHERE MEANS ALLOW. MAXIMUM AIR GAP SHALL NOT EXCEED 2".
 - 5.2. TIES SHALL EXTEND A MIN OF 1-½" INTO THE VENEER, AND HAVE AT LEAST ⅝" COVER FROM THE EXTERIOR FACE.
 - 5.3. SPACE ANCHORS AS INDICATED, BUT NO MORE THAN 16" O.C. VERTICALLY AND 24" O.C. HORIZONTALLY, WITH NOT LESS THAN ONE ANCHOR FOR EVERY 2.67 SF OF WALL AREA. INSTALL ADDITIONAL ANCHORS WITHIN 12" OF OPENINGS AND AT INTERVALS, NOT EXCEEDING 36 IN, AROUND PERIMETER.
 - 5.4. FASTENERS SHALL BE ABLE TO RESIST 130 LBS IN EITHER TENSION/COMPRESSION PERPENDICULAR TO THE WALL SURFACE.
 - 5.4.1. RECOMMENDED ANCHORS (CONTRACTOR SHALL SELECT ANY ANCHORAGE THAT MEETS THE QUALIFICATIONS WITHIN THIS SECTION, HOWEVER; RECOMMENDATIONS HAVE BEEN MADE):
 - 5.4.1.1. HECKMANN BUILDING PRODUCTS
 - 5.4.1.1.1. HECKMANN THE ORIGINAL POS-I-TIE ® BRICK VENEER ANCHORING SYSTEM w/ No. 75 POS-I-TIE ® SELF-DRILLING STEEL STUD SCREW.
 - 5.4.1.1.2. DOUBLE PENTLE PLATE VENEER ANCHOR w/ (2) SELF DRILLING SCREW ANCHORS PER MANUF.
 - 5.4.1.2. HOHMANN & BARNARD, INC.
 - 5.4.1.2.1. 2-SEAL BYNA-LOK WIRE TIE w/ 2-SEAL TIE SELF DRILLING STUD SCREW
 - 5.4.1.2.2. HB-213 ADJUSTABLE VENEER ANCHOR w/ (2) SELF DRILLING SCREWS PER MANUF.
 - 5.4.1.3. WIRE BOND
 - 5.4.1.3.1. SURE TIE ANCHORING SYSTEM w/ SURE TIE 2½" SELF DRILLING ANCHOR SCREW
 - 5.4.1.3.2. RJ-711 ADJUSTABLE VENEER ANCHOR w/ (2) SELF DRILLING SCREWS PER MANUF.
- 5.5. MATERIALS SHALL COMPLY WITH THE FOLLOWING:
 - 5.5.1. ASTM A 36/A36M-14 STANDARD SPECIFICATION FOR CARBON STRUCTURAL STEEL.
 - 5.5.2. ASTM A1008/A1008M SHEET METAL ANCHORS AND TIES (PLAIN STEEL)
 - 5.5.3. ASTM A1064/1064M COLD DRAWN STEEL WIRE
 - 5.5.4. ASTM A153/A153M-16 STANDARD SPECIFICATION FOR ZINC COATING (HOT-DIP) ON IRON AND STEEL HARDWARE
 - 5.5.5. STAINLESS STEEL AISI [TYPE 304] [OR] [TYPE 316]
 - 5.5.6. ASTM A240/A240M-15B STANDARD SPECIFICATION FOR CHROMIUM AND CHROMIUM NICKEL STAINLESS STEEL PLATE, SHEET METAL.
 - 5.5.7. AND STRIP FOR PRESSURE VESSELS AND FOR GENERAL APPLICATION.
 - 5.5.8. ASTM A666-15 STANDARD SPECIFICATION FOR ANNEALED OR COLD-WORKED AUSTENITIC STAINLESS STEEL SHEET, STRIP, PLATE, AND FLAT BAR.
 - 5.5.9. ASTM A580/A580M-15 STANDARD SPECIFICATION FOR STAINLESS STEEL WIRE
 - 5.5.10. ASTM A641/641M-09A (2014) STANDARD SPECIFICATION FOR ZINC-COATED (MILL GALVANIZED) CARBON STEEL WIRE.
 - 5.5.11. ASTM A653/A653M-11 STANDARD SPECIFICATION FOR STEEL SHEET, ZINC-COATED (MILL GALVANIZED)

SGS | **TEC SERVICES**
 Testing • Engineering • Consulting
 SGS NORTH AMERICA, INC (SGS TEC SERVICES)
 235 BUFORD DR, LAWRENCEVILLE, GA 30046
 770.995.8000 | Brian.Wolfe@SGS.COM

REVISIONS		
No.	DESCRIPTION	DATE
0	90% SET FOR BID	03-NOV-23

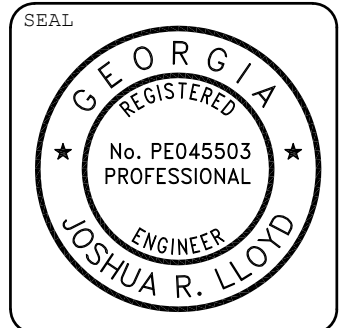

PROJECT: **SHALLOWFORD ANNEX MASONRY & WATERPROOFING RESTORATION**
 4470 N Shallowford Rd, Atlanta, GA
CITY OF DUNWOODY PARKS DEPT.

SHEET DESCRIPTION: **GENERAL NOTES**

PROJECT No.:	SGS22131
DRAWN BY:	JLE22606
CHECK BY:	JRL
DATE:	03-NOV-23

SHEET No.
R3

MATERIALS (Continued)

- 6. WALL SYSTEM COMPONENTS
 - 6.1. BASE WALL SYSTEM
 - 6.1.1. INTERIOR WALLBOARD:
 - 6.1.1.1. 1-LAYER, OR TO MATCH EXISTING, 5/8" TYPE X GYPSUM WALLBOARD
 - 6.1.2. STEEL STUD FRAMING:
 - 6.1.2.1. CLARK-DIETRICH 6" STUD, 600S200-43 w/ CP60 COMPLIANT PROTECTIVE COATING, MAXIMUM 12" O.C. SPACING
 - 6.1.3. STUD CAVITY INSULATION:
 - 6.1.3.1. OWENS CORNING EcoTouch PINK FIBERGLAS INSULATION (UNFACED)
 - 6.1.4. EXTERIOR WALL SHEATHING:
 - 6.1.4.1. GYPSUM SHEATHING, 5/8" TYPE X EXTERIOR GRADE. ALL JOINTS AND FASTENER LOCATIONS SHALL BE SEALED WITH JOINT & SEAM FILLER (SUCH AS PROSOCO R-GUARD)
 - 6.5.5. AIR AND WEATHER BARRIER LAYER OVER GYPSUM SHEATHING
 - 6.5.5.1. FLUID APPLIED, PERMEABLE BARRIER (SUCH AS PROSOCO R-GUARD CAT 5)
 - 6.5.6. THROUGH WALL FLASHING
 - 6.5.4.1. MORTAR NET SOLUTIONS TOTALFLASH, MORTARNET, MPE-1 AND WEEPVENT.
 - 6.6.5. MASONRY VENEER ANCHORS & FASTENERS (SEE SECTION 5)
 - 6.6.6. EXTERIOR CLADDING (SEE SECTIONS 3 & 4)
 - 7. COATINGS
 - 7.1. EXTERIOR MASONRY SURFACE COATING:
 - 7.1.1. BASF MASTER BUILDERS - MasterProtect 170CR;
 - 7.1.2. SIKA CORP - Sika Duo Chem 7500;
 - 7.2. STEEL COATING:
 - 7.2.1. TNAMEC PAINT SYSTEM OR EQUIVALENT
 - 7.2.2. SHERWIN-WILLIAMS DURA-PLATE OR APPROVED ALTERNATE
6. CONTRACTION JOINTS
 - 6.1. WATSON BOWMAN WaboHSeal (EH) (FV WIDTH w/ MANUF)
 - 6.2. OR APPROVED EQUIVALENT
7. SEALANTS
 - 7.1. BACKER ROD - BI-CELLULAR NON-GASSING
 - 7.2. POLYURETHANE JOINTS SEALANTS (EXPOSED)
 - 7.2.1. BASF MasterSeal NP1
 - 7.2.2. SIKA Sikaflex 2c NS TG
 - 7.1. SEALANT/EXPANSION JOINT NOSING (IF REQUIRED):
 - a. WABO WaboCrete II POLYURETHANE EXPANSION JOINT NOSING w/ SEALANT JOINT (ABOVE)
 - b. OR ENGINEER APPROVED EQUIVALENT
8. METAL FLASHING
 - 8.1. DO NOT STOP FLASHING BEHIND BRICK WORK.
 - 8.2. EXTEND FLASHING VERTICALLY UP THE BACKING TO 8" MIN. HEIGHT
 - 8.3. LAP ALL FLASHING JOINTS 4" MIN. UNDER WATER RESISTANT MEMBRANE MATERIAL
 - 8.4. TURN UP FLASHING ENDS INTO HEAD JOINT A MIN. OF 2" TO FORM END DAMS.
 - 8.5. FLASHING SHOULD BE WATERPROOF, DURABLE, CORROSION RESISTANT COATED, AND SHOULD NOT BE INSTALLED TO OVER EXPOSE THE MEMBER TO SUNLIGHT.

ADJ	ADJACENT
AGGR	AGGREGATE
ALUM	ALUMINUM
APPROX	APPROXIMATE
ARCH	ARCHITECTURAL
ASPH	ASPHALT
ASTM	AMERICAN SOCIETY FOR TESTING & MATERIALS
BLDG	BUILDING
BOT	BOTTOM
BRG	BEARING
BTB	BACK-TO-BACK
CC	CENTER-TO-CENTER
CF	CUBIC FEET
CIP	CAST IRON PIPE
CL OR CLR	CENTERLINE
CL	CLEAR
COL	COLUMN
CONT	CONTINUOUS
CONC	CONCRETE
CY	CUBIC YARD
D	DEPTH
DET	DETAIL
DIA OR Ø	DIAMETER
DIM	DIMENSIONS
DIP	DUCTILE IRON PIPE
DIR	DIRECTION
DIST	DISTANCE
DWG	DRAWING
EA	EACH
EBL	EAST BOUND LANE
EFFL	EFFLORESCENCE
ELEC	ELECTRIC
ELEV	ELEVATION
ENGR	ENGINEER
ENTR	ENTRANCE
EOP	EDGE OF PAVEMENT
EOS	EDGE OF SLAB
EQUIP	EQUIPMENT
ETD	EXISTING TO BE DEMOLISHED
ETR	EXISTING TO REMAIN
ETRP	EXISTING TO BE REPLACED
EW	END WALL
EXT	EXISTING
EXTR	EXTERIOR
FD	FLOOR DRAIN
FF	FIRST FLOOR
FG	FINISH GRADE
FPS	FEET PER SECOND
FT	FOOT/FEET
F/T	FREEZE THAW
GR	GUARD RAIL

ABBREVIATIONS

H	HEAD
HDG	HOT DIPPED GALVANIZED
HORZ	HORIZONTAL
HT	HEIGHT
ID	INSIDE DIAMETER
IN	INCH
INTR	INTERIOR
INV	INVERT
JNT	JOINT
L	LENGTH
LAT	LATERAL
LF	LINEAR FEET
LL	LOWER LEVEL
MAX	MAXIMUM
MECH	MECHANICAL
MI	MILE
MIN	MINIMUM
MISC	MISCELLANEOUS
N/A	NOT APPLICABLE
No. OR #	NUMBER
OC OR O.C.	ON CENTER
OBJ	OBJECT
OD	OUTSIDE DIAMETER
OH OR O.H.	OVERHEAD
OPP	OPPOSITE
PERM	PERIMETER
PG	PAGE
PL	PLATE
PRELIM	PRELIMINARY
PROP	PROPOSED
PT	POST-TENSIONING
PVMT	PAVEMENT
QTY	QUANTITY
R	RADIUS
RCP	REINFORCED CONCRETE PIPE
RD	ROAD
REINF	REINFORCEMENT
REQ'D	REQUIRED
REQ'S	REQUIREMENTS
RET	RETAINING
REV	REVISION
R&S	ROUTE AND SEAL
SECT	SECTION
SF	SQUARE FEET
SPEC	SPECIFICATIONS
STD	STANDARD
STR	STRUCTURE
SQ	SQUARE
SQY	SQUARE YARD

TAN	TANGENT
TEMP	TEMPORARY
TOB	TOP OF BEAM
T.O.B.	TOP OF BEAM
TOC	TOP OF COLUMN
T.O.C.	TOP OF COLUMN
TOS	TOP OF SLAB
T.O.S.	TOP OF SLAB
TOW	TOP OF WALL
T.O.W.	TOP OF WALL
TYP	TYPICAL
UND	UNDER
UOB	UNDERSIDE OF BEAM
U.O.B.	UNDERSIDE OF BEAM
VOL	VOLUME
VAR	VARIES
WT	WEIGHT
(E)	EXISTING
(ETR)	EXISTING TO REMAIN
(N)	NEW
(#)	QUANTITY
(TYP)	TYPICAL

REVISIONS		
No.	DESCRIPTION	DATE
0	90% SET FOR BID	03-NOV-23

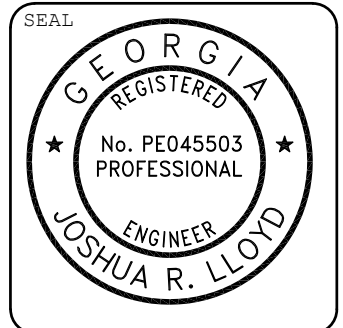

PROJECT: **SHALLOWFORD ANNEX MASONRY & WATERPROOFING RESTORATION**
 4470 N Shallowford Rd, Atlanta, GA
CITY OF DUNWOODY PARKS DEPT.

GENERAL NOTES

SHEET DESCRIPTION:

PROJECT No.: **SGS22131**
JLE22606
 DRAWN BY: **JRL**
 CHECK BY: **JRL**
 DATE: **03-NOV-23**

SHEET No.
R4



1200 FIXED WINDOW
SECTION 08 51 13
ALUMINUM WINDOWS

PART 1 GENERAL

1.01 RELATED DOCUMENTS

1. SECTION 07 92 13 (07900) - JOINT SEALANTS
2. SECTION 08 80 00 (08800) - GLASS AND GLAZING
3. DIVISION 08 SECTION "ALUMINUM-FRAMED ENTRANCES AND STOREFRONTS" FOR COORDINATING FINISH AMONG ALUMINUM FENESTRATION UNITS.
4. DIVISION 08 SECTION "GLAZING" FOR ADDITIONAL GLAZING REQUIREMENTS FOR ALUMINUM WINDOWS.
5. DIVISION 08 SECTION "GLAZED ALUMINUM CURTAIN WALLS" FOR INCORPORATING ALUMINUM WINDOWS INTO GLAZED CURTAIN WALLS AND FOR COORDINATING FINISH AMONG FENESTRATION UNITS.

1.02 SUMMARY

- A. SECTION INCLUDES:
1. ALUMINUM PRIME WINDOWS:
 - a. TYPE: FIXED
 - b. CATEGORY: ARCHITECTURAL (AW)
 - c. DESIGNATION: F-AW65 FIXED (STANDARD AND ARCTIC)

1.03 DEFINITIONS

- A. PERFORMANCE CLASS DESIGNATIONS ACCORDING TO AAMA/WDMA/CSA 101/I.S.2/A440-08:
1. AW: ARCHITECTURAL
- B. PERFORMANCE GRADE NUMBER ACCORDING TO AAMA/WDMA/CSA 101/I.S.2/A440-08:
1. DESIGN PRESSURE NUMBER IN POUNDS PER SQUARE FOOT (PASCALS) USED TO DETERMINE THE STRUCTURAL TEST PRESSURE AND WATER TEST PRESSURE.
- C. STRUCTURAL TEST PRESSURE: FOR UNIFORM LOAD STRUCTURAL TEST, IS EQUIVALENT TO 150 PERCENT OF THE DESIGN PRESSURE.
- D. MINIMUM TEST SIZE: SMALLEST SIZE PERMITTED FOR PERFORMANCE CLASS (GATEWAY TEST SIZE) OR AS SPECIFIED ELSEWHERE IN THIS SECTION, WHICHEVER IS MORE STRINGENT. PRODUCTS MUST BE TESTED AT MINIMUM TEST SIZE OR AT A SIZE LARGER THAN MINIMUM TEST SIZE TO COMPLY WITH THE REQUIREMENTS FOR PERFORMANCE CLASS. DOWNSIZED TEST REPORTS WILL NOT BE CONSIDERED ACCEPTABLE.

1.04 TESTING AND PERFORMANCE REQUIREMENTS

- A. GENERAL:
1. PROVIDE ALUMINUM WINDOWS CAPABLE OF COMPLYING WITH PERFORMANCE REQUIREMENTS INDICATED, BASED ON TESTING MANUFACTURER'S WINDOWS THAT ARE REPRESENTATIVE OF THOSE SPECIFIED, AND THAT ARE OF MINIMUM TEST SIZE INDICATED BELOW:
 - a. FIXED WINDOWS: 60" X 99" (OR SELECTED MANUFACTURERS TESTING PANEL, FOR ENGINEER APPROVAL)
- B. TEST PROCEDURES AND PERFORMANCE:
1. SPECIFICATIONS FOR WINDOWS, DOORS AND UNIT SKYLIGHTS: AAMA 101.
 2. AIR INFILTRATION TEST: ASTM E 283, AT 6.27 PSF STATIC AIR PRESSURE DIFFERENTIAL. AIR INFILTRATION SHALL NOT EXCEED 0.10 CFM PER SQ. FT.
 3. WATER RESISTANCE TEST: ASTM E 331, NO WATER LEAKAGE AT 12 PSF STATIC AIR PRESSURE DIFFERENTIAL.
 4. UNIFORM LOAD DEFLECTION TEST: ASTM E 330, AT STATIC AIR PRESSURE OF +/- 100 PSF. NO MEMBER SHALL DEFLECT MORE THAN 1/175 OF ITS SPAN.
 6. UNIFORM LOAD STRUCTURAL TEST: ASTM E 330, AT STATIC AIR PRESSURE DIFFERENCE OF +/- 150 PSF.
 7. CONDENSATION RESISTANCE TEST: AAMA 1503.1, CRF CLASS SHALL BE NOT LESS THAN C65.
 8. THERMAL TRANSMITTANCE TEST: AAMA 1503.1, U-FACTOR SHALL BE 0.35 TO 0.60.
 9. FORCED ENTRY: F10

1.05 REFERENCES

- A. AAMA (AMERICAN ARCHITECTURAL MANUFACTURERS ASSOCIATION)
- B. ANSI (AMERICAN NATIONAL STANDARDS INSTITUTE)
- C. ASTM (AMERICAN SOCIETY FOR TESTING AND MATERIALS)
- D. GANA (GLASS ASSOCIATION OF NORTH AMERICA)

1.06 SUBMITTALS

- A. PROVIDE SUBMITTALS IN A TIMELY MANNER TO MEET REQUIRED CONSTRUCTION COMPLETION SCHEDULE AND IN ACCORDANCE WITH SPECIFICATIONS.
- B. PRODUCT DATA:
1. INCLUDE CONSTRUCTION DETAILS, MATERIAL DESCRIPTIONS, FABRICATION METHODS, DIMENSIONS OF INDIVIDUAL COMPONENTS AND PROFILES, HARDWARE, FINISHES, AND OPERATING INSTRUCTIONS FOR EACH TYPE OF ALUMINUM WINDOW INDICATED.
- C. SHOP DRAWINGS:
1. INCLUDE PLANS, ELEVATIONS, SECTIONS, DETAILS, HARDWARE, ATTACHMENTS TO OTHER WORK, OPERATIONAL CLEARANCES, INSTALLATION DETAILS, AND THE FOLLOWING:
 - a. MULLION DETAILS, INCLUDING REINFORCEMENT AND STIFFENERS.
 - b. JOINERY DETAILS.
 - c. WEATHER-STRIPPING DETAILS.
 - d. THERMAL-BREAK DETAILS.
 - e. GLAZING DETAILS.
 2. SHOW COMPONENTS COMPLETE WITH DIMENSIONS, MATERIAL AND DETAILS OF ANCHORING AND FASTENING.
 3. SHOW FINISHES, SEALANTS AND OTHER INFORMATION INDICATING COMPLIANCE WITH SPECIFICATIONS.
 4. SUBMIT TEST REPORT PER 1.04 TESTING AND PERFORMANCE REQUIREMENTS.
- D. SAMPLES:
1. COMPONENTS: SUBMIT SAMPLES OF ANCHORS, FASTENERS, HARDWARE, ASSEMBLED CORNER SECTIONS AND OTHER MATERIALS AND COMPONENTS IF REQUESTED BY ENGINEER.
 2. FINISH: SUBMIT FULL RANGE COLOR SAMPLES FOR APPROVAL BY ENGINEER.
- E. MAINTENANCE DATA: FOR FINISHES TO BE INCLUDED IN MAINTENANCE MANUALS.
- F. WARRANTIES: SUBMIT WRITTEN COPIES IN ACCORDANCE WITH SECTION 1.10 WARRANTIES.

1.07 QUALITY ASSURANCE

- A. PROJECT QUALIFICATIONS: IN ORDER TO CONFIRM THAT THE PROPOSED PRODUCT(S) CONFORM TO THE MATERIAL AND PERFORMANCE REQUIREMENTS CONTAINED IN THESE SPECIFICATIONS, BIDDERS SHALL INCLUDE THE FOLLOWING WITH THEIR BID. FAILURE TO COMPLY WITH THESE REQUIREMENTS SHALL CAUSE THE BID TO AUTOMATICALLY BE REJECTED.
1. BIDDERS ACKNOWLEDGEMENT: BIDDERS SHALL INCLUDE A LETTER IN THEIR BID STATING THE MANUFACTURER AND SERIES (MODEL) NUMBER OF THE PRODUCT UPON WHICH ITS BID HAS BEEN BASED. CHANGES IN PRODUCT (MANUFACTURER OR SERIES) WILL NOT BE PERMITTED AFTER THE BID
 2. PRODUCT DATA: BIDDERS SUBMITTING BIDS BASED ON PRODUCTS OTHER THAN THE BASIS OF DESIGN PRODUCT LISTED IN PARAGRAPH 2.1 MUST ALSO INCLUDE THE FOLLOWING WITH THEIR BID:
 - a. COMPREHENSIVE TEST REPORTS NOT MORE THAN FOUR YEARS OLD PREPARED BY A QUALIFIED TESTING AGENCY FOR EACH PRODUCT TYPE BEING USED ON THE PROJECT DEMONSTRATING COMPLIANCE WITH THE AIR, WATER AND STRUCTURAL REQUIREMENTS OUTLINED HEREIN. TEST REPORTS BASED ON THE USE OF DOWNSIZED TEST UNITS WILL NOT BE ACCEPTED.
 - b. THERMAL SIMULATIONS PREPARED BY A QUALIFIED INDEPENDENT TESTING AGENCY FOR EACH PRODUCT TYPE BEING USED ON THE PROJECT DEMONSTRATING COMPLIANCE WITH THE THERMAL TRANSMITTANCE REQUIREMENTS OUTLINED IN PARAGRAPH 2.3.
 - c. FULL SIZE PRODUCT DETAILS SHOWING ALL FRAME AND SASH DETAILS, DIMENSIONS, THERMAL BREAK CONSTRUCTION, WALL THICKNESSES AND JOINERY. DETAILS MUST ACCURATELY REFLECT ALL GLAZING AND HARDWARE OPTIONS SPECIFIED HEREIN.
 3. PRODUCT REQUIREMENTS: FOR MAXIMUM PERFORMANCE, WINDOWS FOR THIS PROJECT MUST MEET BOTH THE TESTING REQUIREMENTS AS CONTAINED HEREIN AND THE MINIMUM MATERIAL REQUIREMENTS SPECIFIED. WINDOWS THAT CARRY THE APPLICABLE AAMA RATING BUT DO NOT MEET THE MATERIAL THICKNESSES, DEPTHS, ETC. SHALL NOT BE ACCEPTABLE FOR USE ON THIS PROJECT.
 4. INSTALLER QUALIFICATIONS: AN INSTALLER ACCEPTABLE TO ALUMINUM WINDOW MANUFACTURERS FOR INSTALLATION OF UNITS REQUIRED FOR THIS PROJECT

SGS | **TEC SERVICES**
Testing • Engineering • Consulting
SGS NORTH AMERICA, INC (SGS TEC SERVICES)
235 BUFORD DR, LAWRENCEVILLE, GA 30046
770.995.8000 | Brian.Wolfe@SGS.COM

REVISIONS		
No.	DESCRIPTION	DATE
0	90% SET FOR BID	03-NOV-23

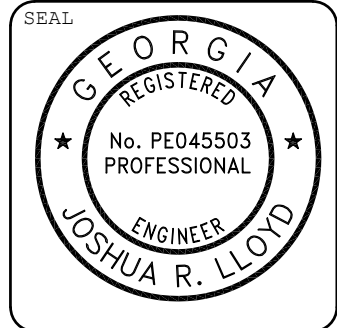

PROJECT: **SHALLOWFORD ANNEX MASONRY & WATERPROOFING RESTORATION**
4470 N Shallowford Rd, Atlanta, GA
CITY OF DUNWOODY PARKS DEPT.

SHEET DESCRIPTION: **GENERAL WINDOW SPECIFICATION**

PROJECT No.: **SGS22131**
DRAWN BY: **JLE22606**
CHECK BY: **JRL**
DATE: **03-NOV-23**

SHEET No.
R5

1.07 QUALITY ASSURANCE (CONTINUED)

5. SOURCE LIMITATIONS: OBTAIN ALUMINUM WINDOWS THROUGH ONE SOURCE FROM A SINGLE MANUFACTURER.
6. PRODUCT OPTIONS: DRAWINGS INDICATE SIZE, PROFILES, AND DIMENSIONAL REQUIREMENTS OF ALUMINUM WINDOWS AND ARE BASED ON THE SPECIFIC SYSTEM INDICATED. DO NOT MODIFY SIZE AND DIMENSIONAL REQUIREMENTS.
 - a. DO NOT MODIFY INTENDED AESTHETIC EFFECTS, AS JUDGED SOLELY BY ENGINEER, EXCEPT WITH ENGINEER'S APPROVAL. IF MODIFICATIONS ARE PROPOSED, SUBMIT COMPREHENSIVE EXPLANATORY DATA TO ENGINEER FOR REVIEW.
7. FENESTRATION STANDARD: COMPLY WITH AAMA/WDMA/CSA 101/I.S.2/A440-08, "STANDARD/SPECIFICATION FOR WINDOWS, DOORS, AND UNIT SKYLIGHTS" FOR DEFINITIONS AND MINIMUM STANDARDS OF PERFORMANCE, MATERIALS, COMPONENTS, ACCESSORIES, AND FABRICATION. COMPLY WITH MORE STRINGENT REQUIREMENTS IF INDICATED.
8. GLAZING PUBLICATIONS: COMPLY WITH PUBLISHED RECOMMENDATIONS OF GLASS MANUFACTURERS AND WITH GANA'S "GLAZING MANUAL" UNLESS MORE STRINGENT REQUIREMENTS ARE INDICATED.
9. PREINSTALLATION CONFERENCE: IF REQUESTED, CONDUCT A CONFERENCE AT PROJECT SITE TO REVIEW METHODS AND PROCEDURES RELATED TO ALUMINUM WINDOWS INCLUDING, BUT NOT LIMITED TO, THE FOLLOWING.
 - a. REVIEW AND FINALIZE CONSTRUCTION SCHEDULE AND VERIFY AVAILABILITY OF MATERIALS, INSTALLER'S PERSONNEL, EQUIPMENT, AND FACILITIES NEEDED TO MAKE PROGRESS AND AVOID DELAYS.
 - b. REVIEW, DISCUSS, AND COORDINATE THE INTERRELATIONSHIP OF ALUMINUM WINDOWS WITH OTHER EXTERIOR WALL COMPONENTS.
 - c. REVIEW AND DISCUSS THE SEQUENCE OF WORK REQUIRED TO CONSTRUCT A WATERTIGHT AND WEATHERTIGHT EXTERIOR BUILDING ENVELOPE.
 - d. INSPECT AND DISCUSS THE CONDITION OF SUBSTRATE AND OTHER PREPARATORY WORK PERFORMED BY OTHER TRADES.

1.08 PROJECT CONDITIONS

- A. FIELD MEASUREMENTS: FOR RETROFIT INSTALLATIONS, VERIFY ALUMINUM WINDOW OPENINGS BY FIELD MEASUREMENTS BEFORE FABRICATION AND INDICATE MEASUREMENTS ON SHOP DRAWINGS.
 1. ESTABLISHED DIMENSIONS: WHERE FIELD MEASUREMENTS CANNOT BE MADE WITHOUT DELAYING THE WORK, ESTABLISH OPENING DIMENSIONS AND PROCEED WITH FABRICATING ALUMINUM WINDOWS WITHOUT FIELD MEASUREMENTS. COORDINATE WALL CONSTRUCTION TO ENSURE THAT ACTUAL OPENING DIMENSIONS CORRESPOND TO ESTABLISHED DIMENSIONS.

1.09 DELIVERY, STORAGE AND HANDLING

- A. PROTECT MATERIALS FROM DAMAGE BEFORE INSTALLATION PER INSTRUCTIONS AND IN ACCORDANCE WITH SPECIFICATIONS.

1.10 WARRANTIES

- A. WINDOW SYSTEM:
 1. QUALIFIED WINDOW MANUFACTURER, WITH PROVEN FINANCIAL RESPONSIBILITY AND YEARS OF EXPERIENCE OF AT LEAST THE LENGTH OF THE WARRANTY PERIOD SHALL PROVIDE WRITTEN **5 OR 10 YEAR WARRANTY** AGAINST DEFECTS IN MATERIALS AND WORKMANSHIP.
 2. FAILURES INCLUDE, BUT ARE NOT LIMITED TO, THE FOLLOWING:
 - a. FAILURE TO MEET PERFORMANCE REQUIREMENTS.
 - b. STRUCTURAL FAILURES INCLUDING EXCESSIVE DEFLECTION, WATER LEAKAGE, OR AIR INFILTRATION.
 - c. DETERIORATION OF METALS OR OTHER MATERIALS BEYOND THAT WHICH IS NORMAL.
 - d. FAILURE OF INSULATING GLASS.

PART 2 PRODUCTS

2.01 MANUFACTURER

- A. **ARCHITECTURAL WINDOW MANUFACTURING CORPORATION**, RUTHERFORD, NEW JERSEY. THE BASIS OF DESIGN FOR THESE SPECIFICATIONS IS THE SERIES 8090I FIXED.
- B. **OLDCASTLE BUILDINGENVELOPE®**.
- C. **GRAHAM ARCHITECTURAL PRODUCTS**, YORK, PENNSYLVANIA.
- D. ALTERNATE, SEE SECTION 1.07 FOR COMPLIANCE WITH PROJECT STANDARDS.

2.02 MATERIALS

- A. ALUMINUM: ALLOY AND TEMPER RECOMMENDED BY ALUMINUM WINDOW MANUFACTURER FOR STRENGTH, CORROSION RESISTANCE, AND APPLICATION OF REQUIRED FINISH, BUT NOT LESS THAN 22,000-PSI (150-MPA) ULTIMATE TENSILE STRENGTH, NOT LESS THAN 16,000-PSI (110-MPA) MINIMUM YIELD STRENGTH, AND NOT LESS THAN 0.080-INCH (1.6-MM) THICKNESS AT ANY LOCATION FOR THE MAIN FRAME. 6063-T6 ALLOY SHALL HAVE MINIMUM WALL THICKNESS OF 0.062".
 1. EXTRUSIONS: COMPLY WITH ASTM B 221. EXTRUSION TOLERANCES SHALL MEET ANSI H35.2.
 2. SHEET: COMPLY WITH ASTM B 209.
 3. FRAMES:
 - a. DEPTH: 4", 5", OR 6" STANDARD SYSTEM
 - b. DESIGN: EQUAL LEG
 4. THERMAL BARRIER: 9/16" STANDARD SYSTEM CRIMPED IN PLACE RIGID PVC.
- B. HARDWARE: MATERIAL SHALL BE CORROSION RESISTANT AND COMPATIBLE WITH ALUMINUM. HARDWARE MUST PROVE ITS STRENGTH AND SUITABILITY BY BEING INSTALLED ON UNITS THAT ARE TESTED IN ACCORDANCE WITH SPECIFICATIONS.
 1. FASTENERS: PROVIDE NON-MAGNETIC STAINLESS-STEEL SCREWS, EPOXY ADHESIVES, OR OTHER MATERIAL WARRANTED BY THE MANUFACTURER. ALL FASTENERS MUST BE CONCEALED EXCEPT WHERE UNAVOIDABLE FOR APPLICATION OF HARDWARE.
 2. ANCHORS, CLIPS, AND ACCESSORIES: ALUMINUM, NONMAGNETIC STAINLESS STEEL, OR ZINC-COATED STEEL OR IRON COMPLYING WITH ASTM B 633 FOR SC 3 SEVERE SERVICE CONDITIONS; PROVIDE SUFFICIENT STRENGTH TO WITHSTAND DESIGN PRESSURE INDICATED.
- C. GLAZING: WINDOWS SHALL BE FACTORY GLAZED UNLESS TOO LARGE OR UNSAFE FOR HANDLING.
 1. GLASS: PROVIDE IN ACCORDANCE WITH SECTION 08 80 00 (08800).
 2. GLAZING MATERIALS: UNITS SHALL BE EXTERIOR WET GLAZED USING SILICONE CAP BEADS, SETTING BLOCKS, EDGE BLOCKS AND ACCESSORIES AS RECOMMENDED BY AND IN ACCORDANCE WITH GANA GLAZING MANUAL.
- D. WEATHERSTRIPPING: SHALL BE NON-SHRINKING, RESISTANT TO ULTRAVIOLET DEGRADATION, AND REPLACEABLE CLOSED CELL ELASTOMER SHALL MEET ASTM C 509. DENSE ELASTOMER SHALL MEET ASTM C 864.
 1. COMPRESSION-TYPE WEATHER STRIPPING: PROVIDE COMPRESSIBLE WEATHER STRIPPING DESIGNED FOR PERMANENTLY RESILIENT SEALING UNDER BUMPER OR WIPER ACTION AND FOR COMPLETE CONCEALMENT WHEN ALUMINUM WINDOW IS CLOSED. MANUFACTURER'S STANDARD SYSTEM AND MATERIALS COMPLYING WITH AAMA/WDMA/CSA 101/I.S.2/A440-08.
 2. SLIDING-TYPE WEATHER STRIPPING: PROVIDE WOVEN-PILE WEATHER STRIPPING OF WOOL, POLYPROPYLENE, OR NYLON PILE AND RESIN-IMPREGNATED BACKING FABRIC. COMPLY WITH AAMA 701/702. PROVIDE WEATHER STRIPPING WITH INTEGRAL BARRIER FIN OR FINS OF SEMIRIGID, POLYPROPYLENE SHEET OR POLYPROPYLENE-COATED MATERIAL. COMPLY WITH AAMA 701/702.
- E. SEALANTS: COLOR OF EXPOSED SEALANTS SHALL BE COMPATIBLE WITH ADJACENT WINDOW MATERIALS. FOR SEALANTS REQUIRED WITHIN FABRICATED WINDOWS, PROVIDE WINDOW MANUFACTURER'S STANDARD, PERMANENTLY ELASTIC, NONSHRINKING, AND NONMIGRATING TYPE RECOMMENDED BY SEALANT MANUFACTURER FOR JOINT SIZE AND MOVEMENT. COMPLY WITH AAMA 803.3

2.03 WINDOW

- A. WINDOW TYPE: FIXED
- B. AAMA/WDMA PERFORMANCE REQUIREMENTS: PROVIDE ALUMINUM PROVIDE ALUMINUM WINDOWS OF PERFORMANCE INDICATED THAT COMPLY WITH AAMA/WDMA/CSA 101/I.S.2/A440-08.
 1. PERFORMANCE CLASS AND GRADE: AW-PG100 OR BETTER.
- C. CONDENSATION-RESISTANCE FACTOR (CRF), THERMAL TRANSMITTANCE, AIR INFILTRATION, WATER RESISTANCE, AND FORCED-ENTRY RESISTANCE:
 1. SEE SECTION 1.04 FOR PERFORMANCE REQUIREMENTS.

2.03 FABRICATION

- A. FRAMES: SHALL BE MACHINED, MECHANICALLY FASTENED AND SEALED TO FORM A WATERTIGHT JOINT.
- B. COMPONENT FORMING: ALL ALUMINUM COMPONENTS SHALL BE FORMED, FREE OF SCRATCHES AND BURRS, BEFORE APPLICATION OF FINISH.

REVISIONS		
No.	DESCRIPTION	DATE
0	90% SET FOR BID	03-NOV-23

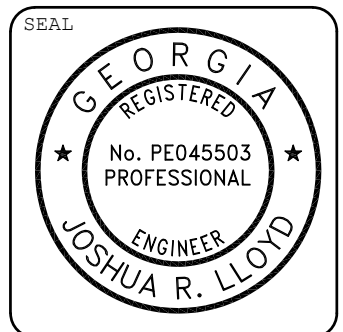

PROJECT: **SHALLOWFORD ANNEX MASONRY & WATERPROOFING RESTORATION**
 4470 N Shallowford Rd, Atlanta, GA
CITY OF DUNWOODY PARKS DEPT.

SHEET DESCRIPTION: **GENERAL WINDOW SPECIFICATION**

PROJECT No.: **SGS22131**
 DRAWN BY: **JLE22606**
 CHECK BY: **JRL**
 DATE: **03-NOV-23**

SHEET No.
R6



2.04 FINISHES

- A. COVER ALL EXPOSED AREAS OF ALUMINUM WINDOWS AND COMPONENTS. OVERALL FINISH SHALL MATCH EXISTING WINDOW FRAMING COMPONENTS ON THE PROPERTY. BASED ON THE TYPE
 - [CLEAR ANODIZED]
 1. TYPE: ARCHITECTURAL CLASS I CLEAR ANODIZING.
 2. AAMA SPECIFICATION: COMPLY WITH AAMA 611.
 3. ALUMINUM ASSOCIATION DESIGNATION: AA_M10_C22_A41.
 4. COLOR: CLEAR 215-R1
 - [COLOR ANODIZED]
 1. TYPE: ARCHITECTURAL CLASS I FOR COLOR ANODIZING.
 2. AAMA SPECIFICATION: COMPLY WITH AAMA 611.
 3. ALUMINUM ASSOCIATION DESIGNATION: AA_M10_C22_A44.
 4. COLOR: **BLACK**

- C. REMEDIATE NONCOMPLIANT WINDOWS AND RETEST AS SPECIFIED ABOVE.
- D. ADDITIONAL TESTING AND INSPECTING, AT CONTRACTOR'S EXPENSE, WILL BE PERFORMED TO DETERMINE COMPLIANCE OF REMEDIATED DOORS OR ADDITIONAL WORK WITH SPECIFIED REQUIREMENTS.

3.04 ADJUSTING AND CLEANING

- A. AFTER INSTALLATION AND TESTING, WINDOWS AND GLAZING SHALL BE INSPECTED, ADJUSTED, AND LEFT CLEAN AND FREE OF LABELS AND DIRT. PROTECT FINISHED INSTALLATION AGAINST DAMAGE.
- B. FINAL CLEANING OF ANODIZED FINISH SHALL BE IN ACCORDANCE WITH AAMA 609.1; PAINTED FINISH SHALL BE IN ACCORDANCE WITH AAMA 610.1.

3.05 DEMONSTRATION

- A. ENGAGE A FACTORY-AUTHORIZED SERVICE REPRESENTATIVE TO TRAIN OWNER'S MAINTENANCE PERSONNEL TO MAINTAIN WINDOW SYSTEM.

END OF SECTION 085113

PART 3 EXECUTION

3.01 INSPECTION

- A. EXAMINE OPENINGS, SUBSTRATES, STRUCTURAL SUPPORT, ANCHORAGE, AND CONDITIONS, WITH INSTALLER PRESENT, FOR COMPLIANCE WITH REQUIREMENTS FOR INSTALLATION TOLERANCES AND OTHER CONDITIONS AFFECTING PERFORMANCE OF WORK. VERIFY ROUGH OPENING DIMENSIONS, LEVELNESS OF SILL PLATE, AND OPERATIONAL CLEARANCES. EXAMINE WALL FLASHINGS, VAPOR RETARDERS, WATER AND WEATHER BARRIERS, AND OTHER BUILT-IN COMPONENTS TO ENSURE A COORDINATED, WEATHERTIGHT WINDOW INSTALLATION.
 1. MASONRY SURFACES: VISIBLY DRY AND FREE OF EXCESS MORTAR, SAND, AND OTHER CONSTRUCTION DEBRIS.
 2. WOOD FRAME WALLS: DRY, CLEAN, SOUND, WELL NAILED, FREE OF VOIDS, AND WITHOUT OFFSETS AT JOINTS. ENSURE THAT NAIL HEADS ARE DRIVEN FLUSH WITH SURFACES IN OPENING AND WITHIN 3 INCHES (76 MM) OF OPEN.
 3. METAL SURFACES: DRY; CLEAN; FREE OF GREASE, OIL, DIRT, RUST, CORROSION, AND WELDING SLAG; WITHOUT SHARP EDGES OR OFFSETS AT JOINTS.
 4. PROCEED WITH INSTALLATION ONLY AFTER UNSATISFACTORY CONDITIONS HAVE BEEN CORRECTED.

3.02 INSTALLATION

- A. INSTALL WINDOWS WITH SKILLED TRADESMAN IN ACCORDANCE WITH APPROVED SHOP DRAWINGS AND SPECIFICATIONS.
- B. UNFINISHED ALUMINUM SHALL BE INSULATED FROM DIRECT CONTACT WITH STEEL, MASONRY CONCRETE, AND NON-COMPATIBLE MATERIALS BY BITUMINOUS PAINT, ZINC CHROMATE PRIMER OR OTHER SUITABLE INSULATING MATERIAL.
- C. INSTALL VAPOR RETARDER/AIR BARRIER IN ACCORDANCE WITH SPECIFICATIONS BETWEEN WINDOW PERIMETER AND ADJOINING COLLATERAL MATERIALS AND EXISTING WALL BARRIERS TO ASSURE CONTINUITY.
- D. PLUMB WINDOW FACES IN A SINGLE PLANE FOR EACH WALL PLANE. ERECT SQUARE AND TRUE. ANCHOR TO MAINTAIN POSITION WHEN SUBJECTED TO NORMAL THERMAL AND BUILDING MOVEMENT, SEISMIC FORCES AND SPECIFIED WIND LOADS.
- E. APPLY SEALANTS AT JOINTS AND INTERSECTIONS AND AT OPENING PERIMETERS IN ACCORDANCE WITH APPROVED SHOP DRAWINGS AND SECTION 07 93 13 (07900) TO PROVIDE WATERTIGHT INSTALLATION.

3.03 FIELD QUALITY CONTROL

- A. TESTING AGENCY: **IF DESIRED, OWNER WILL ENGAGE** A QUALIFIED TESTING AGENCY TO PERFORM TESTS AND INSPECTIONS AND PREPARE TEST REPORTS.
- B. TESTING SERVICES: TESTING AND INSPECTING OF INSTALLED WINDOWS SHALL TAKE PLACE AS FOLLOWS:
 1. TESTING METHODOLOGY: TESTING OF WINDOWS FOR AIR INFILTRATION AND WATER RESISTANCE SHALL BE PERFORMED ACCORDING TO AAMA 502, TEST METHOD [A]. FIELD TEST PRESSURES AND ALLOWABLE LIMITS SHALL BE AS FACTORED BY AAMA 502 FROM THOSE MINIMUMS REQUIRED TO DETERMINE LABORATORY COMPLIANCE WITH THE APPLICABLE PERFORMANCE CLASS AND GRADE PURSUANT TO AAMA/WDMA/CSA 101/I.S.2/A440-08.
 2. TESTING EXTENT: **[ONE]** WINDOW AS SELECTED BY ENGINEER AND A QUALIFIED INDEPENDENT TESTING AND INSPECTING AGENCY. WINDOWS SHALL BE TESTED IMMEDIATELY AFTER INSTALLATION.
 3. TEST REPORTS: SHALL BE PREPARED ACCORDING TO AAMA 502.

SGS | **TEC SERVICES**
 Testing • Engineering • Consulting
 SGS NORTH AMERICA, INC (SGS TEC SERVICES)
 235 BUFORD DR, LAWRENCEVILLE, GA 30046
 770.995.8000 | Brian.Wolfe@SGS.COM

REVISIONS		
No.	DESCRIPTION	DATE
0	90% SET FOR BID	03-NOV-23

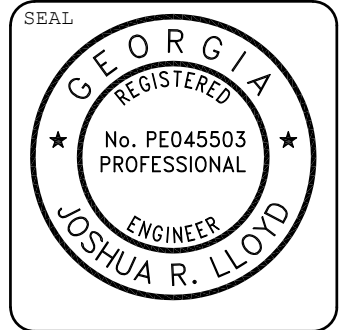

PROJECT: **SHALLOWFORD ANNEX MASONRY & WATERPROOFING RESTORATION**
 4470 N Shallowford Rd, Atlanta, GA
CITY OF DUNWOODY PARKS DEPT.

SHEET DESCRIPTION: **GENERAL WINDOW SPECIFICATION**

PROJECT No.: SGS22131 / JLE22606
 DRAWN BY: JRL
 CHECK BY: JRL
 DATE: 03-NOV-23

SHEET No.
R7

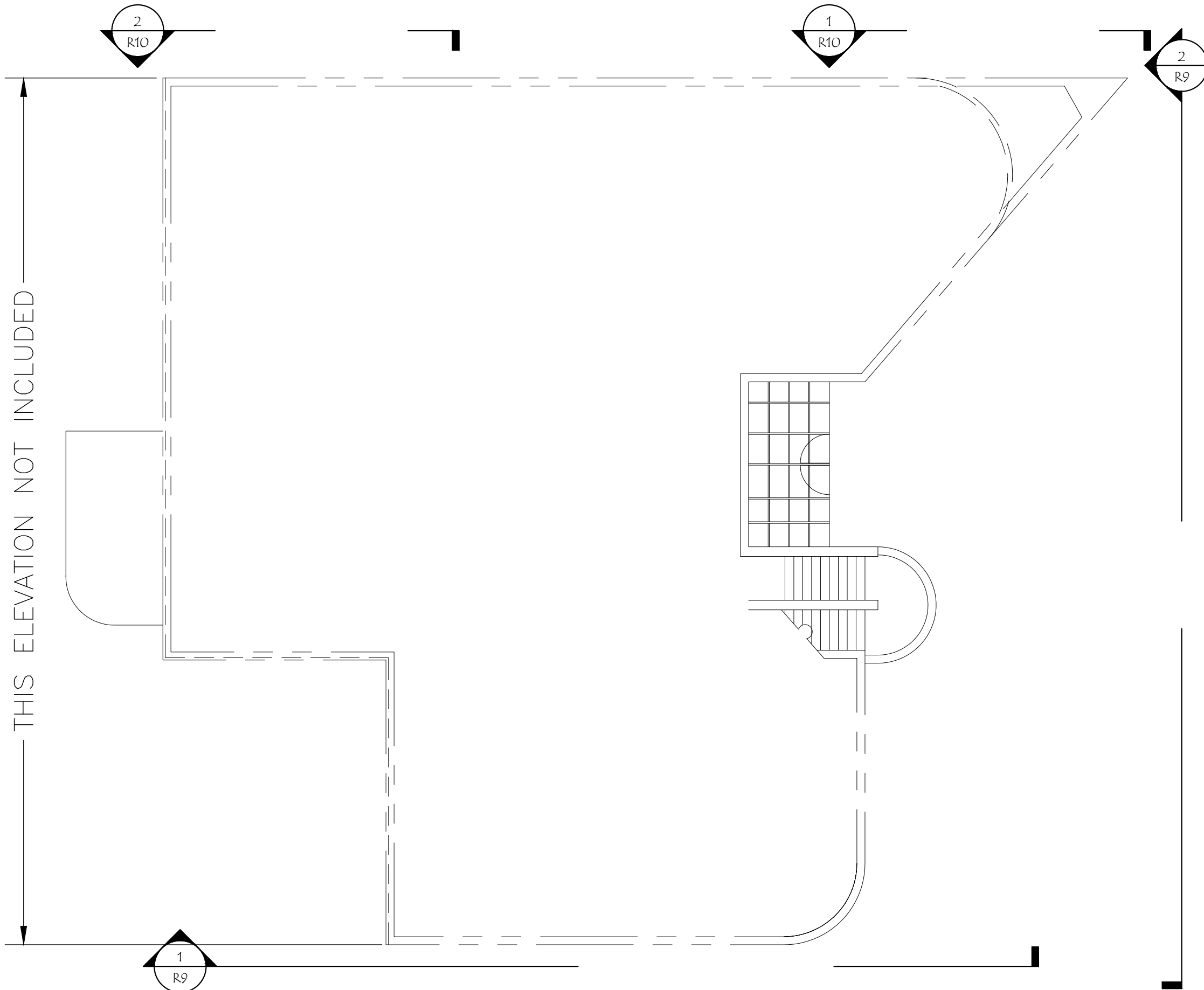

1 PLAN - BUILDING FOOTPRINT FROM GRADE LEVEL
 SCALE: 3/16" = 1'-0"

REVISIONS		
No.	DESCRIPTION	DATE
0	90% SET FOR BID	03-NOV-23

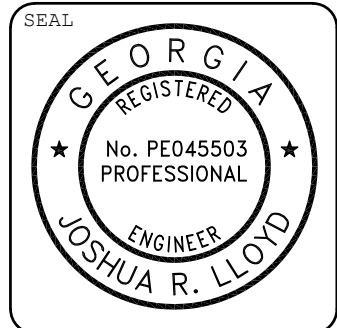

J. LLOYD
 ENGINEERING
 P.O. Box 169, Watkinsville, GA 30677
 404.518.6121 | JRL@Lloyd-Eng.com

PROJECT: **SHALLOWFORD ANNEX MASONRY & WATERPROOFING RESTORATION**
 4470 N Shallowford Rd, Atlanta, GA
 CITY OF DUNWOODY PARKS DEPT.

SHEET DESCRIPTION: **CONDITION ASSESSMENT OBSERVATIONS**

PROJECT No.: SGS22131 / JLE22606
 DRAWN BY: JRL
 CHECK BY: JRL
 DATE: 03-NOV-23

SHEET No.
R8

SGS **TEC SERVICES**
 Testing • Engineering • Consulting
 SGS NORTH AMERICA, INC (SGS TEC SERVICES)
 235 BUFORD DR, LAWRENCEVILLE, GA 30046
 770.995.8000 | Brian.Wolfe@SGS.COM

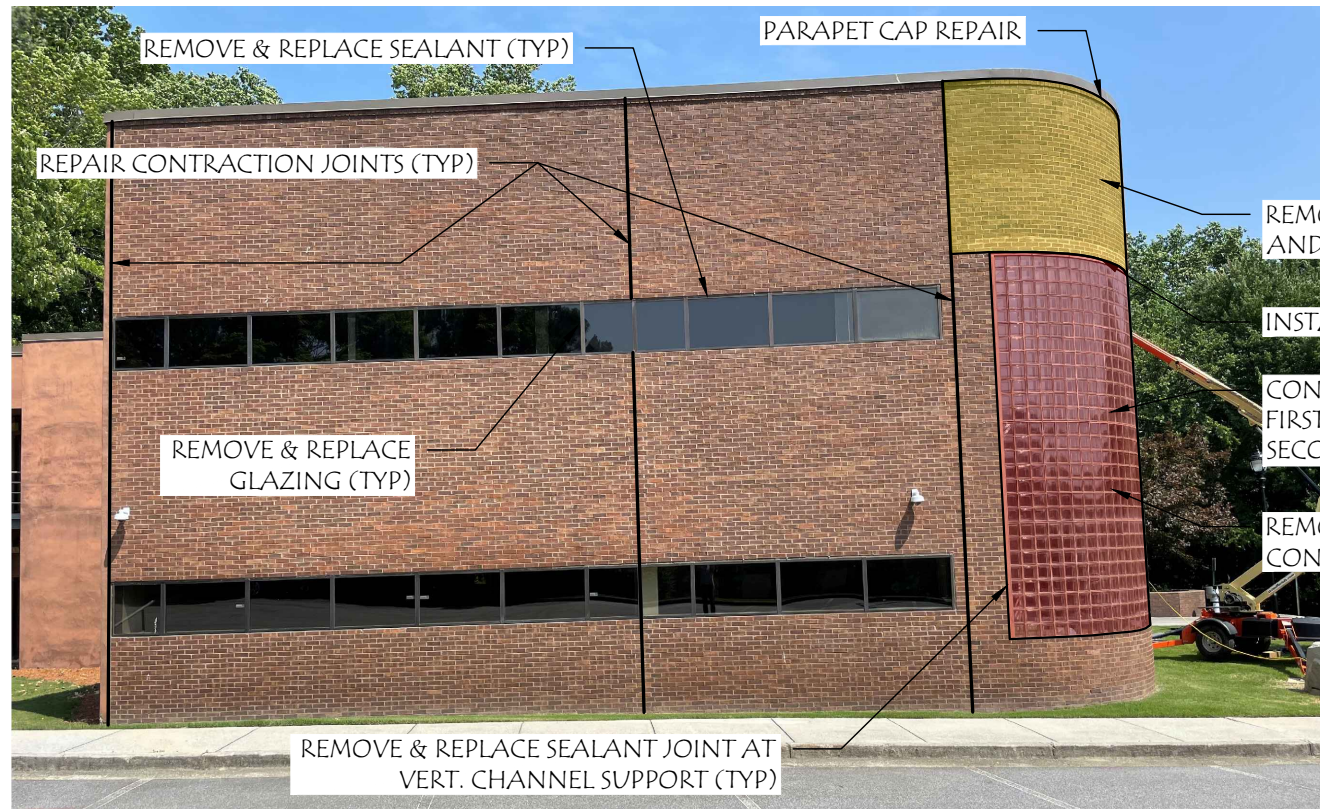

REMOVE & REPLACE SEALANT (TYP)

REPAIR CONTRACTION JOINTS (TYP)

REMOVE & REPLACE GLAZING (TYP)

REMOVE & REPLACE SEALANT JOINT AT VERT. CHANNEL SUPPORT (TYP)

PARAPET CAP REPAIR

REMOVE & REPLACE BRICK VENEER, GYPSUM BOARD, BRICK TIES, AND WATERPROOFING

INSTALL SEALANT JOINTS AT STEEL-TO-MASONRY JOINTS

CONTRACTOR TO PROVIDE SHOP DRAWINGS FOR NEW WINDOWS. FIRST FLOOR WINDOWS, APPROXIMATELY 24" WIDE BY 6'-0" TALL SECOND FLOOR WINDOWS, APPROXIMATELY 24" WIDE BY 4'-0" TALL

REMOVE & REPLACE GLASS BLOCKS w/ METAL STUD WALL AND WINDOWS. CONTRACTOR TO PROVIDE SHOP DRAWINGS FOR NEW STUD WALLS.

1 ELEVATION - SOUTH WALL ELEVATION REPAIRS
SCALE: NOT TO SCALE

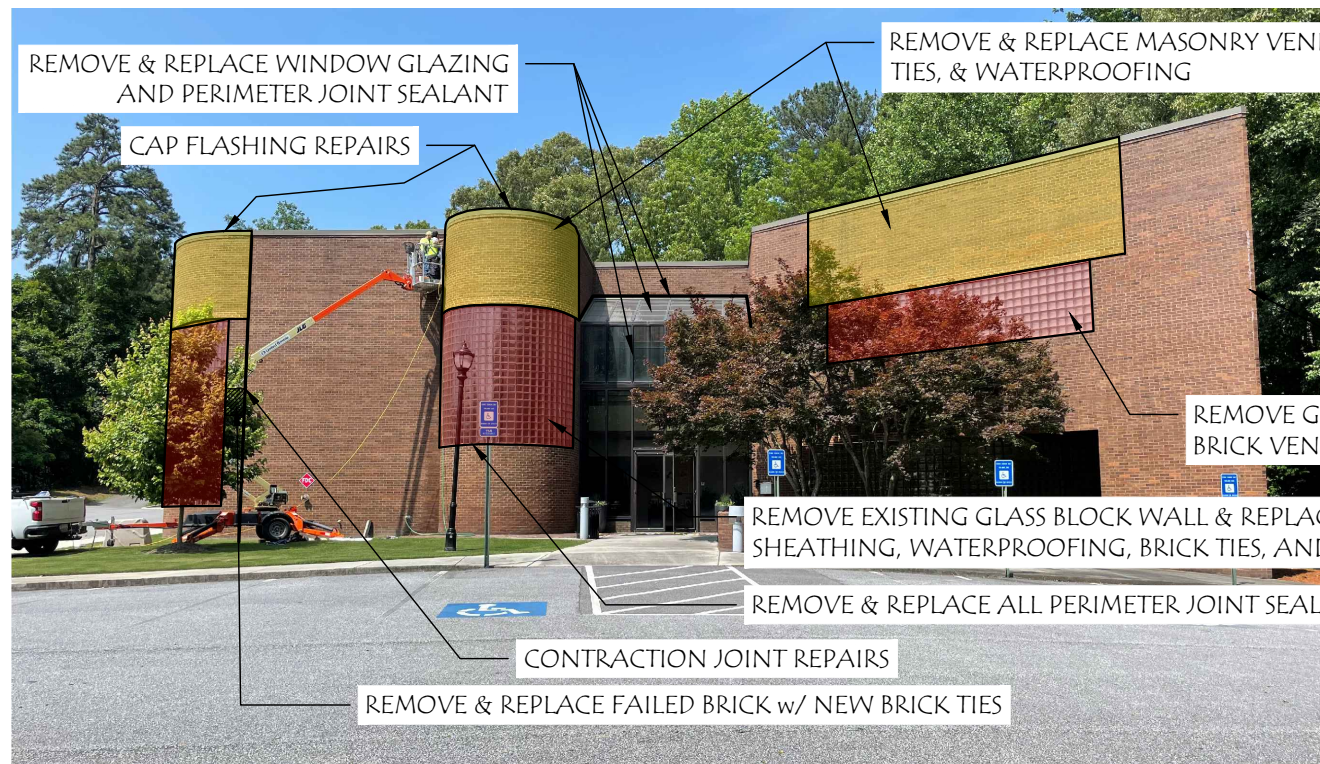

REMOVE & REPLACE WINDOW GLAZING AND PERIMETER JOINT SEALANT

CAP FLASHING REPAIRS

REMOVE & REPLACE MASONRY VENEER, GYPSUM BACKERBOARD, BRICK TIES, & WATERPROOFING

REPOINT END JOINT (TYP)

REMOVE GLASS BLOCK & REPLACE w/ STEEL STUDS AND BRICK VENEER (TO MATCH EXISTING).

REMOVE EXISTING GLASS BLOCK WALL & REPLACE WITH STEEL STUDS, FIRE-RETARDANT SHEATHING, WATERPROOFING, BRICK TIES, AND MASONRY (TO MATCH EXISTING)

REMOVE & REPLACE ALL PERIMETER JOINT SEALANT

CONTRACTION JOINT REPAIRS

REMOVE & REPLACE FAILED BRICK w/ NEW BRICK TIES

2 ELEVATION - EAST WALL ELEVATION REPAIRS
SCALE: NOT TO SCALE

REVISIONS		
No.	DESCRIPTION	DATE
0	90% SET FOR BID	03-NOV-23

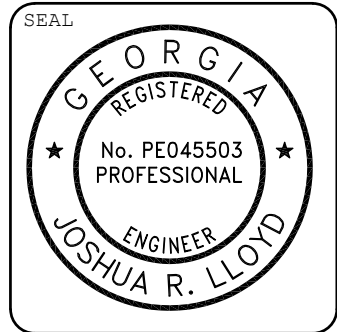

J. LLOYD
ENGINEERING

P.O. Box 169, Watkinsville, GA 30677
404.518.6121 | JRL@Lloyd-Eng.com

PROJECT: **SHALLOWFORD ANNEX MASONRY & WATERPROOFING RESTORATION**
4470 N Shallowford Rd, Atlanta, GA
CITY OF DUNWOODY PARKS DEPT.

SHEET DESCRIPTION: ELEVATIONS

PROJECT No.: SGS22131
JLE22606
DRAWN BY: JRL
CHECK BY: JRL
DATE: 03-NOV-23

SHEET No.
R9

SGS **TEC SERVICES**
Testing • Engineering • Consulting

SGS NORTH AMERICA, INC (SGS TEC SERVICES)
235 BUFORD DR, LAWRENCEVILLE, GA 30046
770.995.8000 | Brian.Wolfe@SGS.COM



REMOVE & REPLACE WINDOW GLAZING AND PERIMETER JOINT SEALANT (TYP)

1 ELEVATION - PARTIAL NORTH WALL ELEVATION REPAIRS
SCALE: NOT TO SCALE

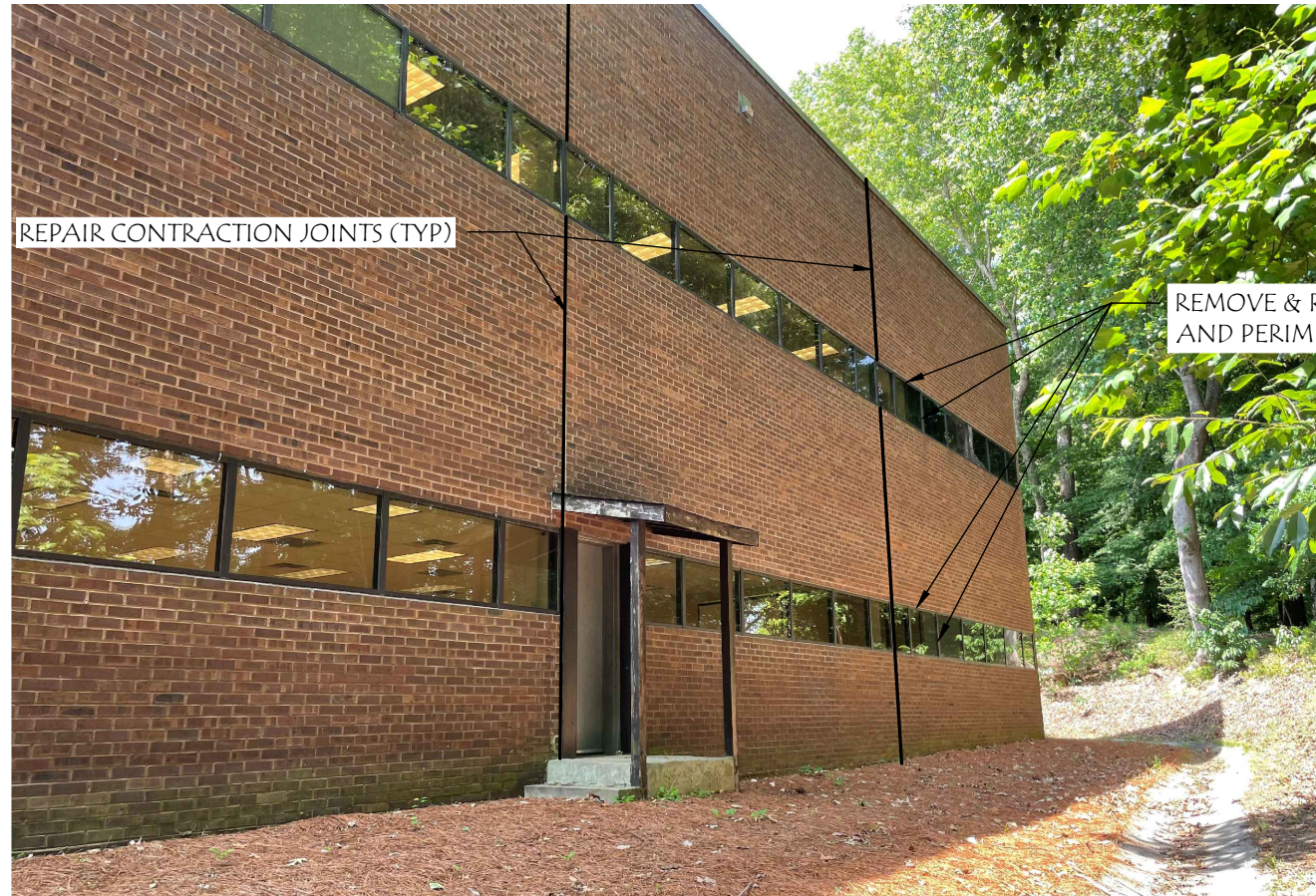

REMOVE & REPLACE WINDOW GLAZING AND PERIMETER JOINT SEALANT (TYP)

2 ELEVATION - PARTIAL NORTH WALL ELEVATION REPAIRS
SCALE: NOT TO SCALE

REVISIONS		
No.	DESCRIPTION	DATE
0	90% SET FOR BID	03-NOV-23



J. LLOYD
ENGINEERING
P.O. Box 169, Watkinsville, GA 30677
404.518.6121 | JRL@Lloyd-Eng.com

PROJECT: **SHALLOWFORD ANNEX MASONRY & WATERPROOFING RESTORATION**
4470 N Shallowford Rd, Atlanta, GA
CITY OF DUNWOODY PARKS DEPT.
SHEET DESCRIPTION: ELEVATIONS

PROJECT No.: SGS22131 / JLE22606
DRAWN BY: JRL
CHECK BY: JRL
DATE: 03-NOV-23

SHEET No.
R10

SGS **TEC SERVICES**
Testing • Engineering • Consulting
SGS NORTH AMERICA, INC (SGS TEC SERVICES)
235 BUFORD DR, LAWRENCEVILLE, GA 30046
770.995.8000 | Brian.Wolfe@SGS.COM

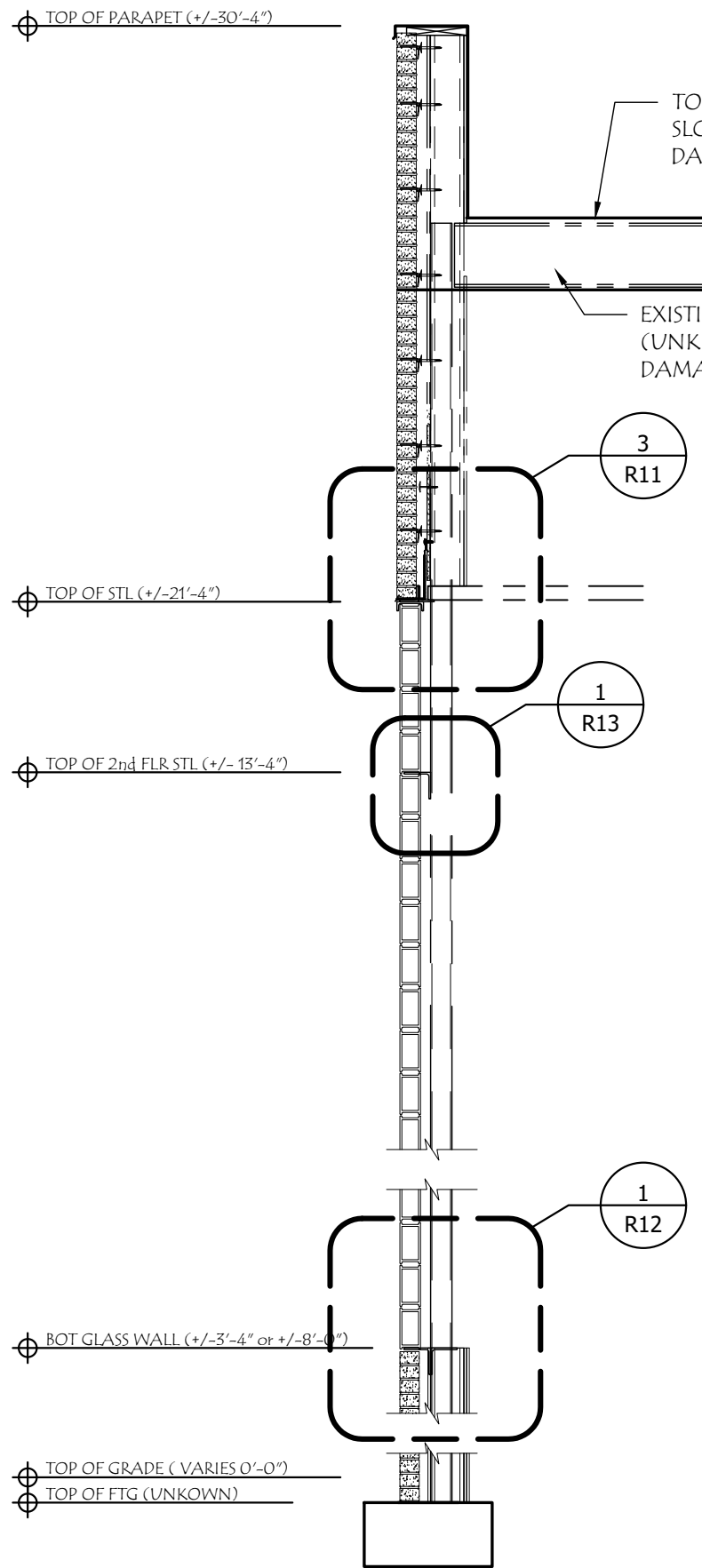

1 SECTION - EXISTING WALL FRAMING DEMO
SCALE: 3/8" = 1'-0"

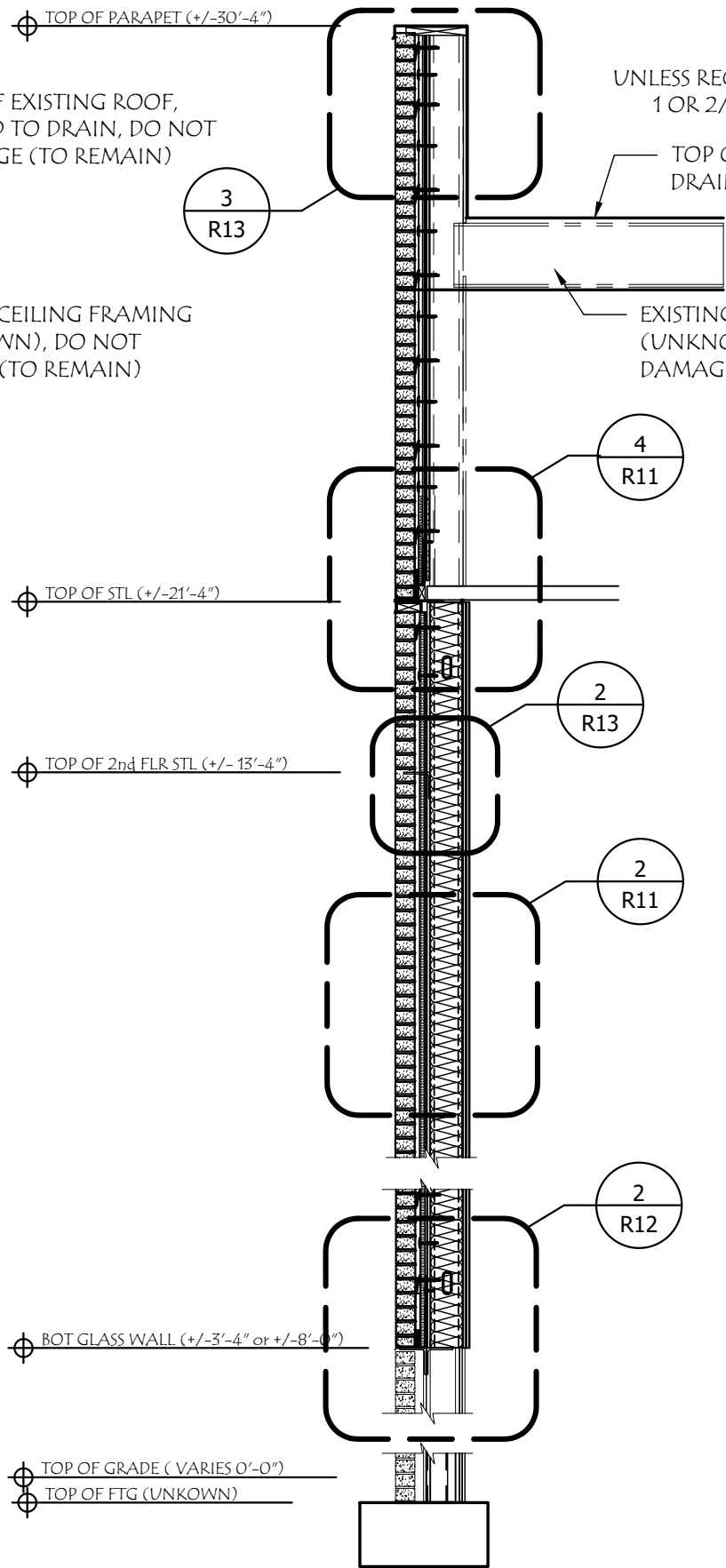

2 SECTION - WALL FRAMING REPAIRS
SCALE: 3/8" = 1'-0"

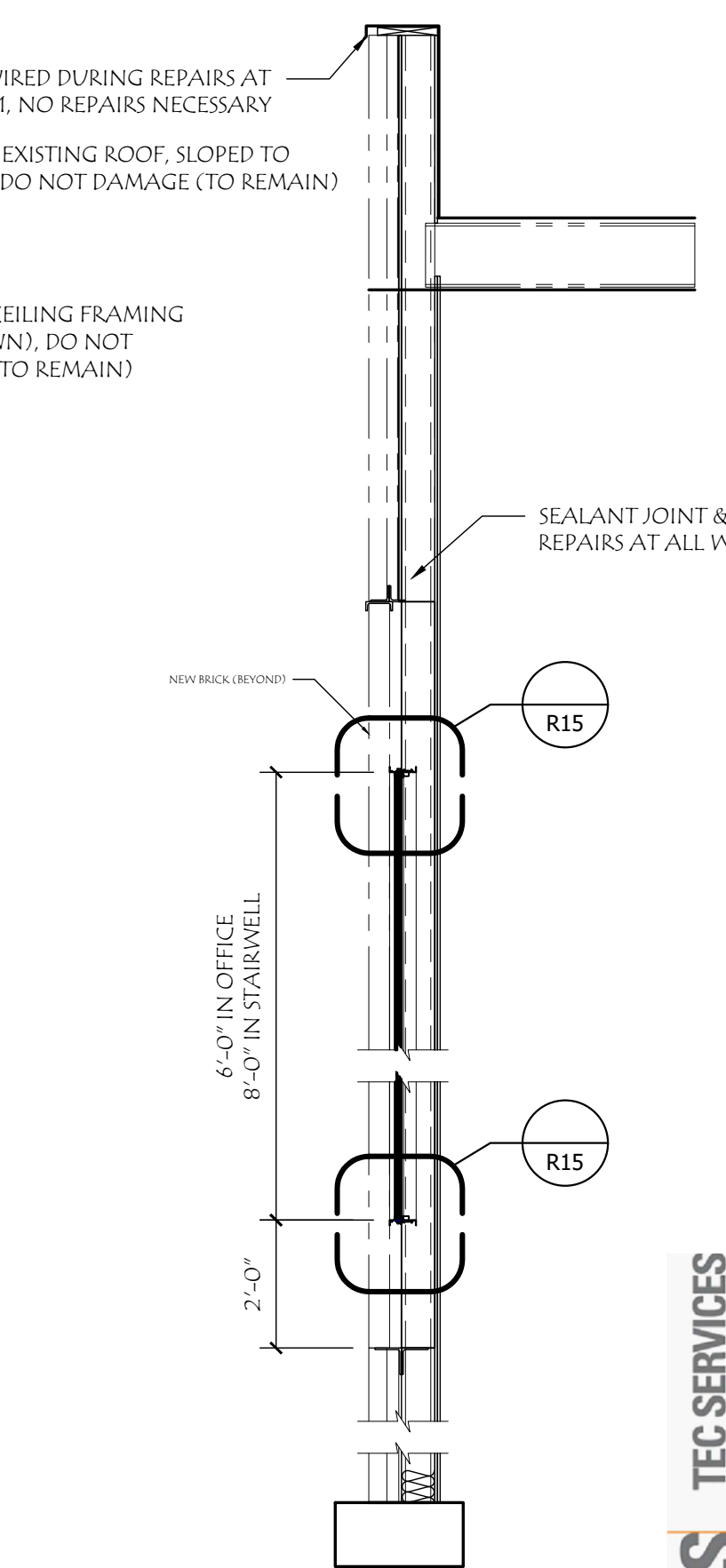

3 SECTION - WALL FRAMING w/ WINDOW
SCALE: 3/8" = 1'-0"

SGS
TEC SERVICES
Testing • Engineering • Consulting
SGS NORTH AMERICA, INC (SGS TEC SERVICES)
235 BUFORD DR, LAWRENCEVILLE, GA 30046
770.995.8000 | Brian.Wolfe@SGS.COM

REVISIONS		
No.	DESCRIPTION	DATE
0	90% SET FOR BID	03-NOV-23

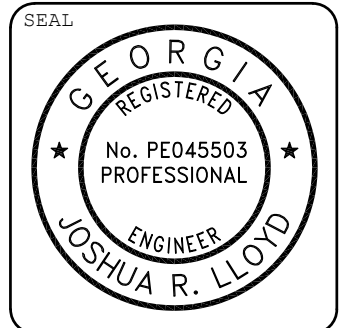

J. LLOYD
ENGINEERING
P.O. Box 169, Watkinsville, GA 30677
404.518.6121 | JRL@Lloyd-Eng.com

PROJECT: **SHALLOWFORD ANNEX MASONRY & WATERPROOFING RESTORATION**
4470 N Shallowford Rd, Atlanta, GA
CITY OF DUNWOODY PARKS DEPT.
SHEET DESCRIPTION: WALL SECTIONS

PROJECT No.: SG522131
DRAWN BY: JLE22606
CHECK BY: JRL
DATE: 03-NOV-23

SHEET No.
R11

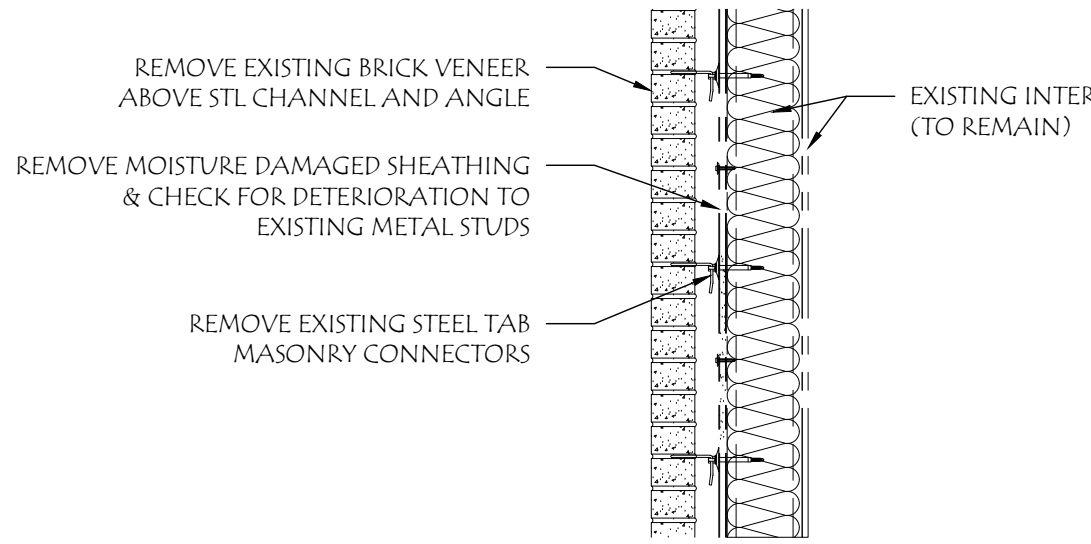

1 TYPICAL DEMO SECTION - EXISTING WALL FRAMING
R12 SCALE: 3/4" = 1'-0"

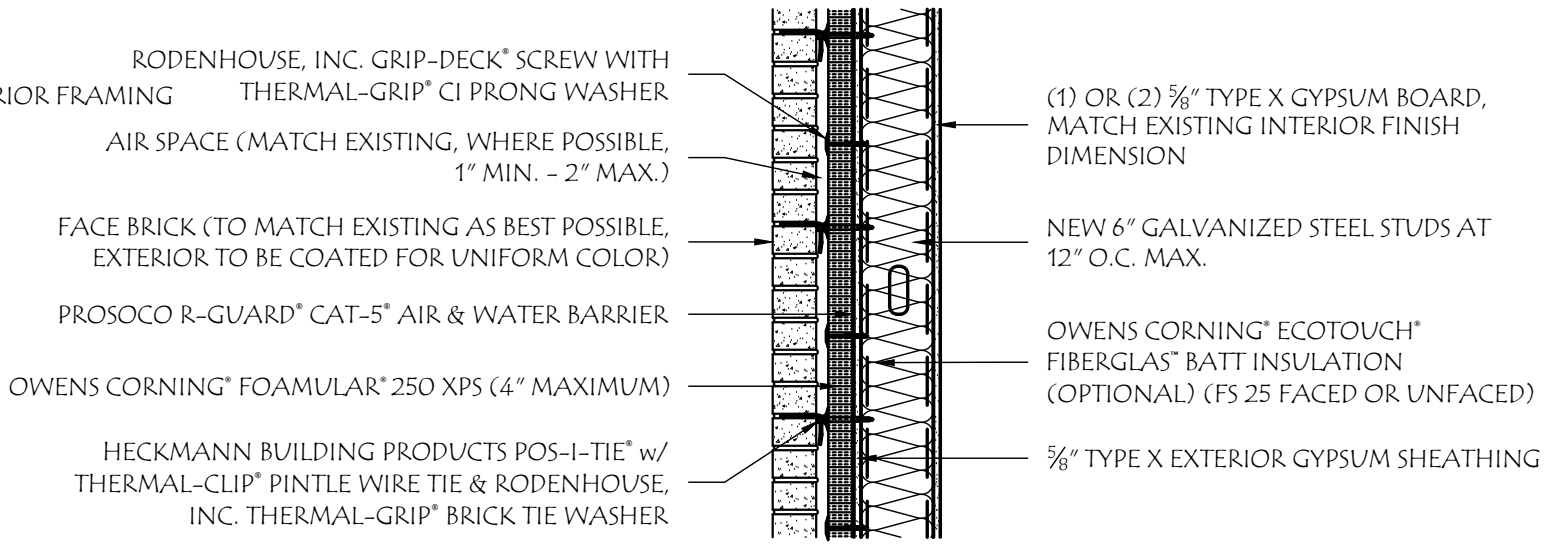

2 TYPICAL REPAIR SECTION - WALL FRAMING w/ NEW BRICK & WATERPROOFING
R12 SCALE: 3/4" = 1'-0"

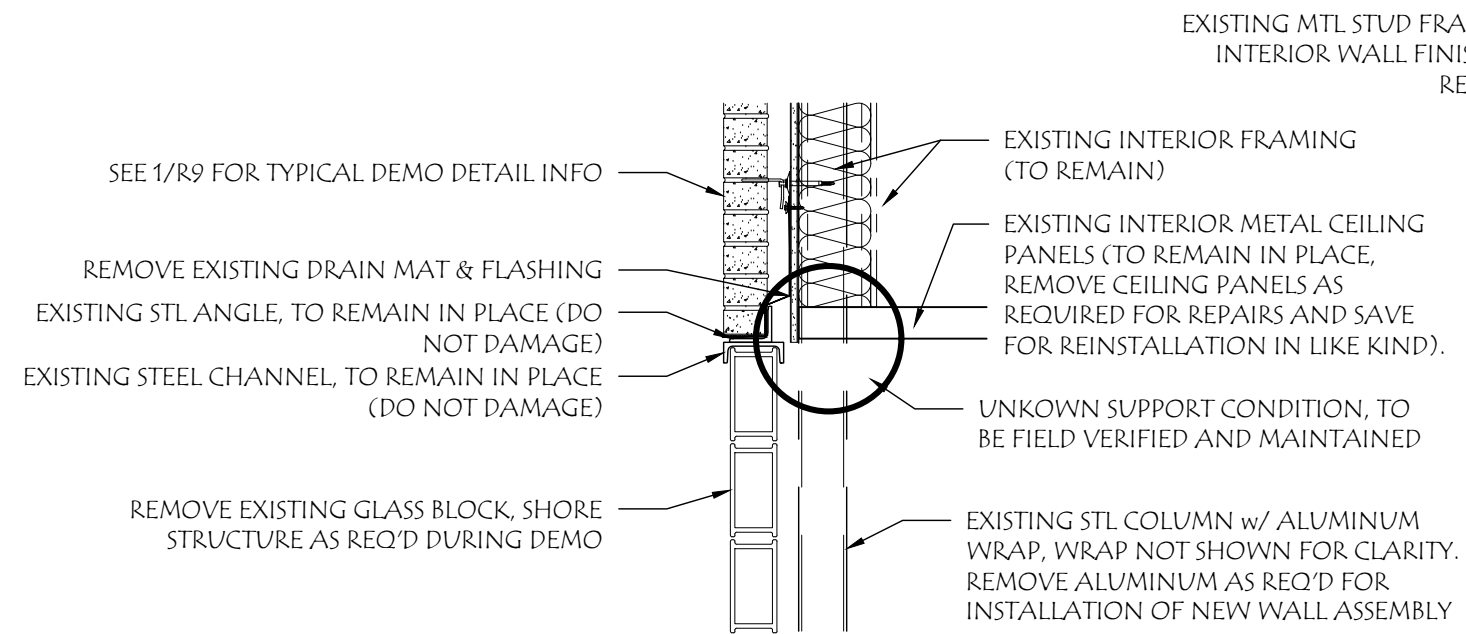

3 TYPICAL DEMO DETAIL - WALL FRAMING AT SILL DETAIL
R12 SCALE: 3/4" = 1'-0"

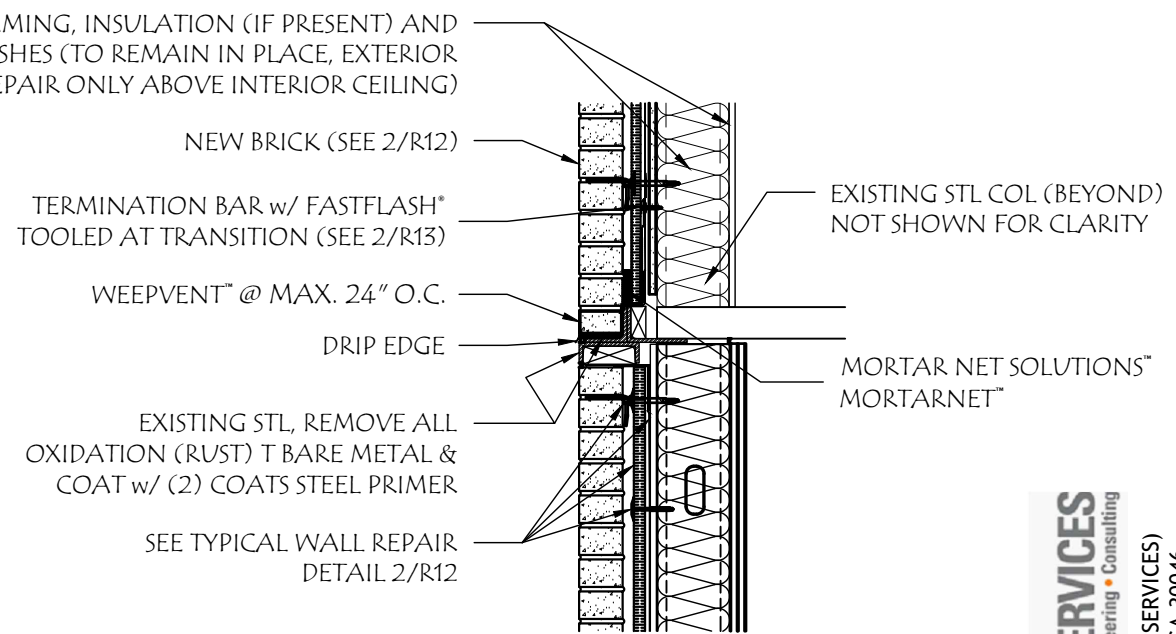

4 TYPICAL REPAIR DETAIL - WALL FRAMING AT SILL
R12 SCALE: 3/4" = 1'-0"

REVISIONS		
No.	DESCRIPTION	DATE
0	90% SET FOR BID	03-NOV-23

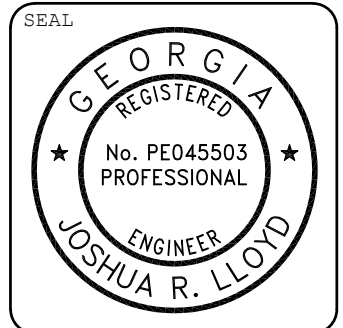

J. LLOYD
ENGINEERING

P.O. Box 169, Watkinsville, GA 30677
404.518.6121 | JRL@Lloyd-Eng.com

PROJECT: **SHALLOWFORD ANNEX MASONRY & WATERPROOFING RESTORATION**
4470 N Shallowford Rd, Atlanta, GA
CITY OF DUNWOODY PARKS DEPT.

SHEET DESCRIPTION: SECTIONS/DETAILS

PROJECT No.:	SGS22131
DRAWN BY:	JLE22606
CHECK BY:	JRL
DATE:	03-NOV-23

SHEET No.
R12

SGS **TEC SERVICES**
Testing • Engineering • Consulting

SGS NORTH AMERICA, INC (SGS TEC SERVICES)
235 BUFORD DR, LAWRENCEVILLE, GA 30046
770.995.8000 | Brian.Wolfe@SGS.COM

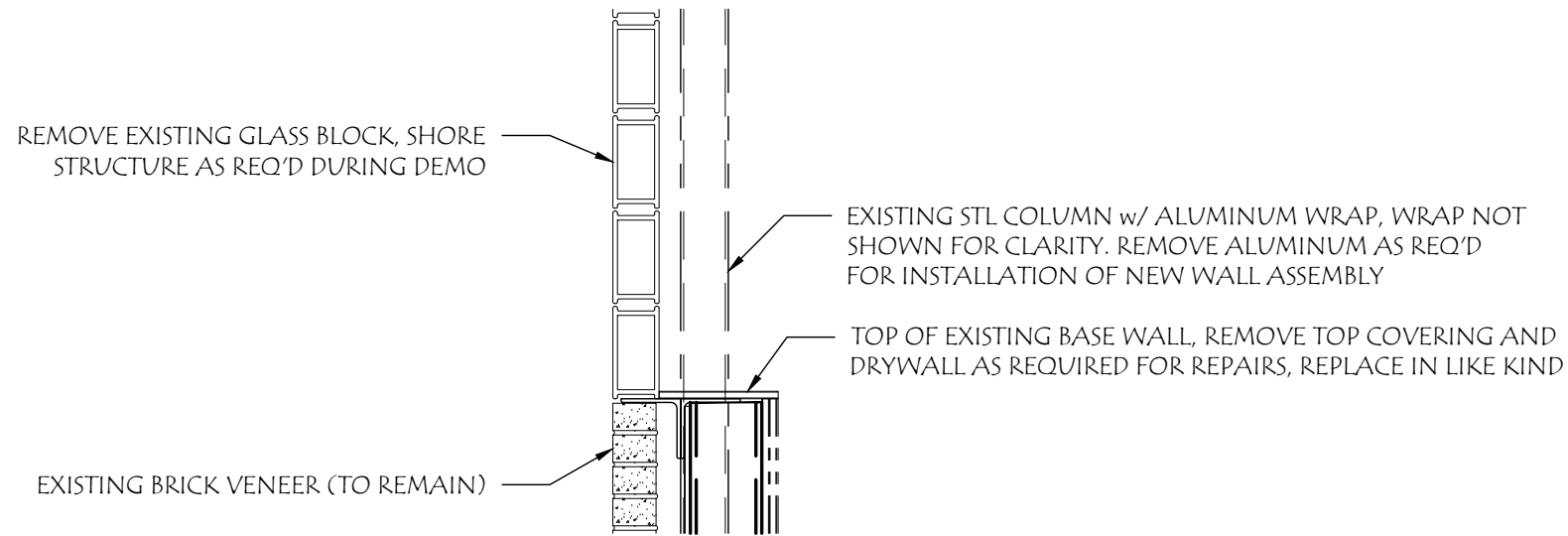

1 TYPICAL DEMO DETAIL - WALL FRAMING AT GLASS BLOCK SILL
 R13 SCALE: 3/4" = 1'-0"

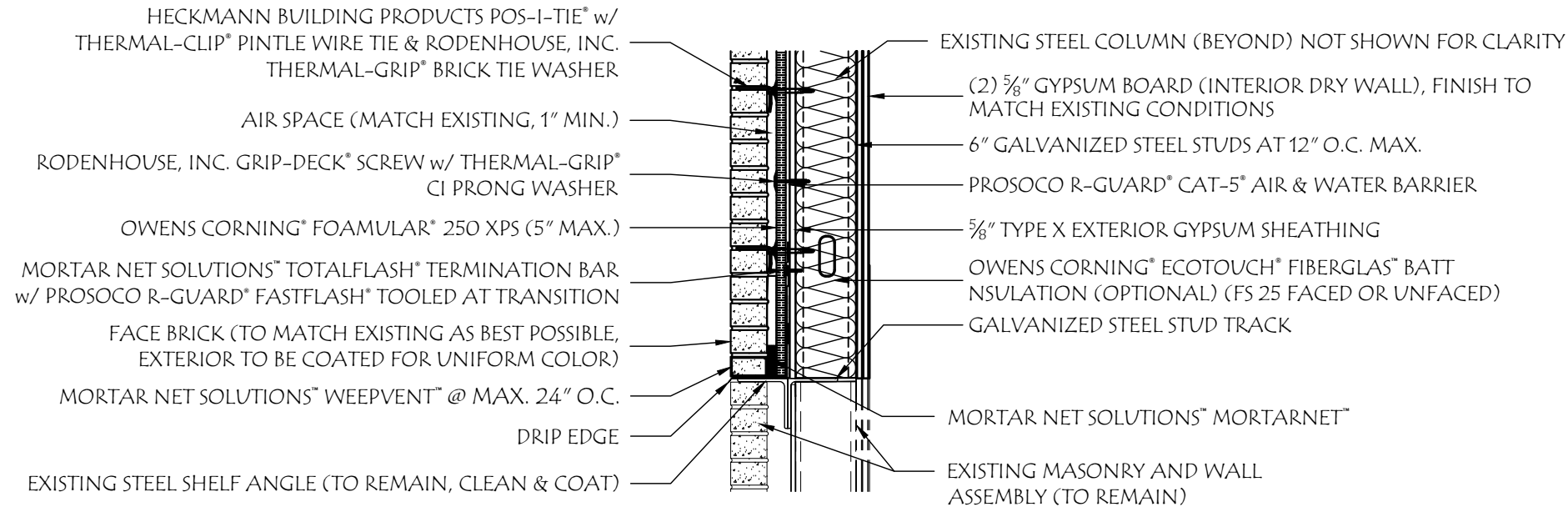

2 TYPICAL REPAIR DETAIL - WALL FRAMING AT BASE OF EXISTING GLASS BLOCK WALL
 R13 SCALE: 3/4" = 1'-0"

REVISIONS		
No.	DESCRIPTION	DATE
0	90% SET FOR BID	03-NOV-23

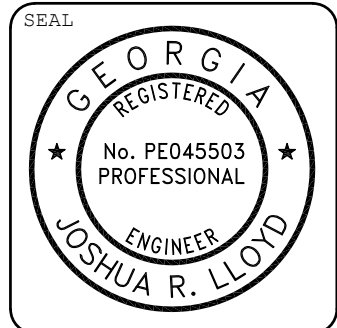

J. LLOYD
 ENGINEERING
 P.O. Box 169, Watkinsville, GA 30677
 404.518.6121 | JRL@Lloyd-Eng.com

PROJECT: **SHALLOWFORD ANNEX MASONRY & WATERPROOFING RESTORATION**
 4470 N Shallowford Rd, Atlanta, GA
 CITY OF DUNWOODY PARKS DEPT.
 SHEET DESCRIPTION: SECTIONS/DETAILS

PROJECT No.: SGS22131
 JLE22606
 DRAWN BY: JRL
 CHECK BY: JRL
 DATE: 03-NOV-23

SHEET No.
R13

SGS **TEC SERVICES**
 Testing • Engineering • Consulting
 SGS NORTH AMERICA, INC (SGS TEC SERVICES)
 235 BUFORD DR, LAWRENCEVILLE, GA 30046
 770.995.8000 | Brian.Wolfe@SGS.COM

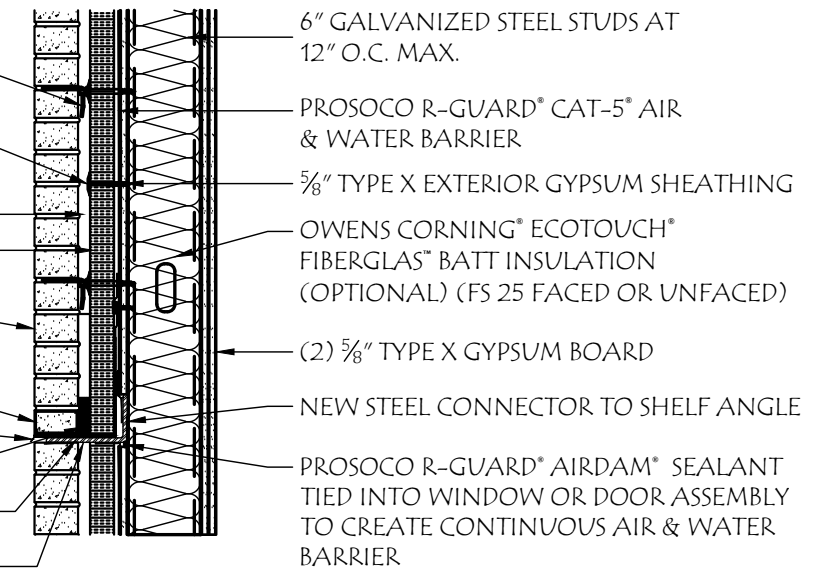
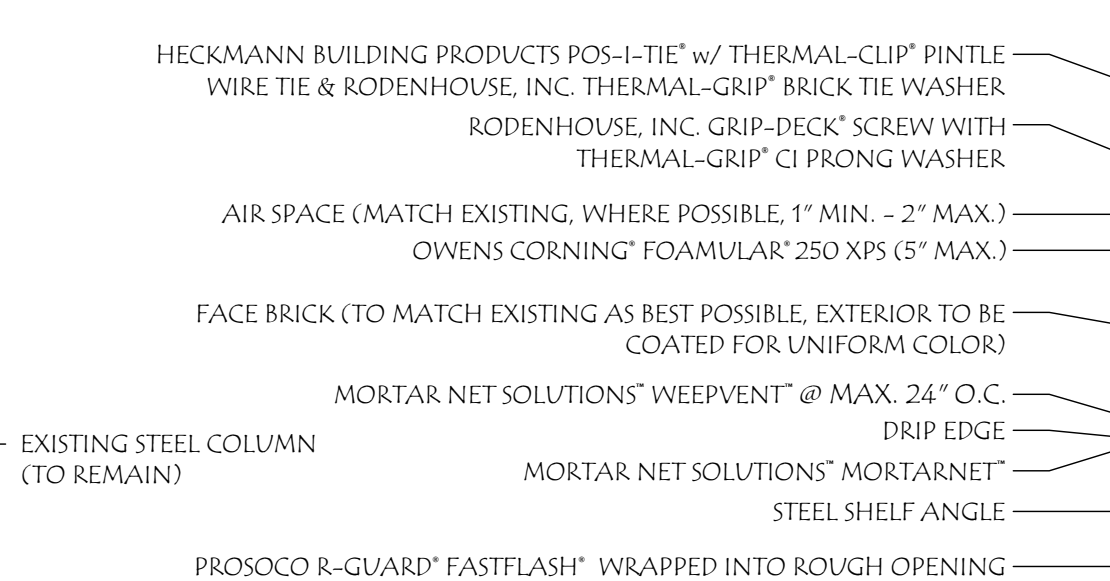
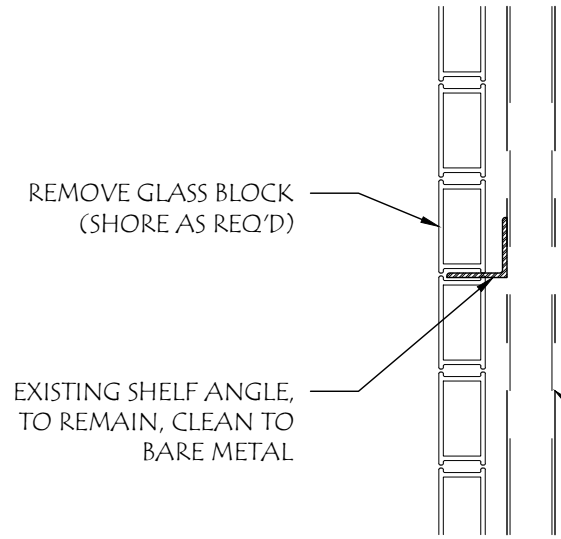

1 TYPICAL DEMO DETAIL - WALL FRAMING AT 2nd FLOOR ANGLE
 R14 SCALE: 6" = 1'-0"

2 TYPICAL REPAIR DETAIL - WALL FRAMING AT 2nd FLOOR SHELF ANGLE
 R14 SCALE: 3/4" = 1'-0"

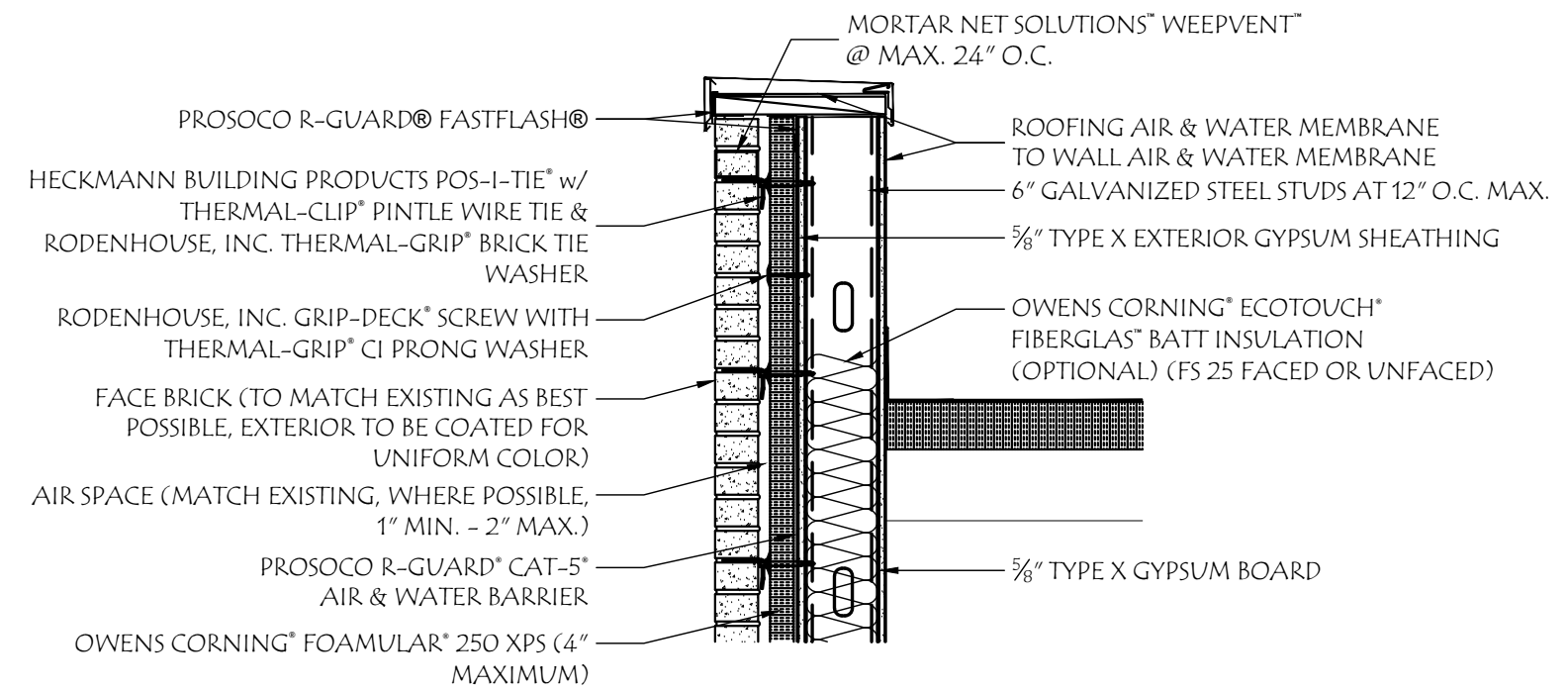

3 TYPICAL - PARAPET WALL FRAMING DETAIL
 R14 SCALE: 6" = 1'-0"

REVISIONS		
No.	DESCRIPTION	DATE
0	90% SET FOR BID	03-NOV-23



J. LLOYD ENGINEERING
 P.O. Box 169, Watkinsville, GA 30677
 404.518.6121 | JRL@Lloyd-Eng.com

PROJECT: **SHALLOWFORD ANNEX MASONRY & WATERPROOFING RESTORATION**
 4470 N Shallowford Rd, Atlanta, GA
 CITY OF DUNWOODY PARKS DEPT.

SHEET DESCRIPTION: SECTIONS/DETAILS

PROJECT No.: SGS22131 / JLE22606
 DRAWN BY: JRL
 CHECK BY: JRL
 DATE: 03-NOV-23

SHEET No.
R14

SGS TEC SERVICES
 Testing • Engineering • Consulting
 SGS NORTH AMERICA, INC (SGS TEC SERVICES)
 235 BUFORD DR, LAWRENCEVILLE, GA 30046
 770.995.8000 | Brian.Wolfe@SGS.COM

REVISIONS

No.	DESCRIPTION	DATE
0	90% SET FOR BID	03-NOV-23

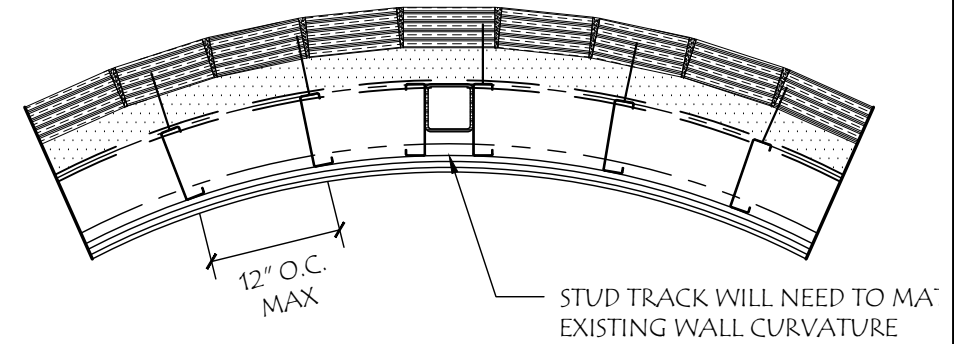
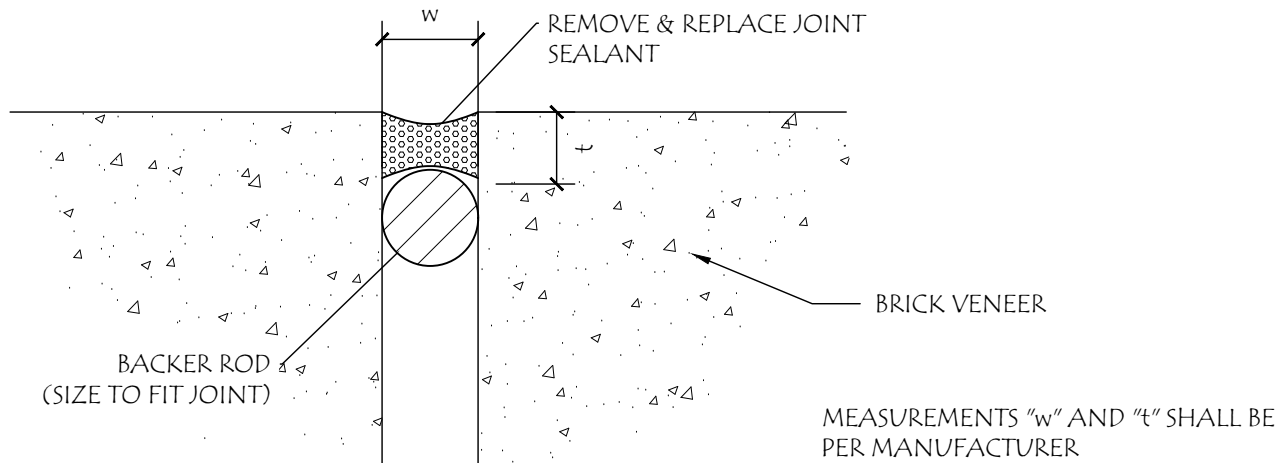

1 TYPICAL - CONTRACTION JOINT SEALANT REPAIR DETAIL
SCALE: NOT TO SCALE

3 TYPICAL - PARTIAL PLAN AT NEW STUD/VENEER WALL
SCALE: NOT TO SCALE

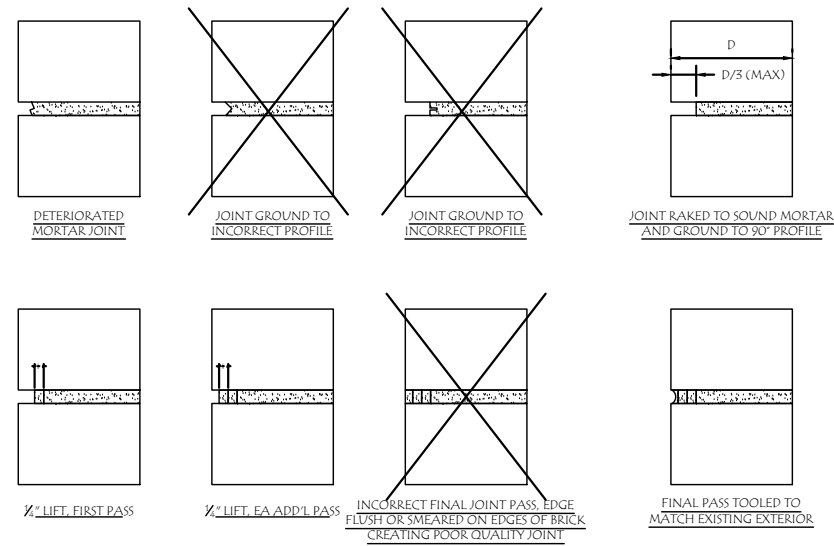

2 DETAIL - REPOINTED BRICK VENEER MORTAR JOINTS
SCALE: NOT TO SCALE

PROJECT: **SHALLOWFORD ANNEX MASONRY & WATERPROOFING RESTORATION**
4470 N Shallowford Rd, Atlanta, GA
CITY OF DUNWOODY PARKS DEPT.

SHEET DESCRIPTION: SECTIONS/DETAILS

PROJECT No.: SGS22131 / JLE22606
DRAWN BY: JRL
CHECK BY: JRL
DATE: 03-NOV-23

SHEET No.
R15

SGS **TEC SERVICES**
Testing • Engineering • Consulting
SGS NORTH AMERICA, INC (SGS TEC SERVICES)
235 BUFORD DR, LAWRENCEVILLE, GA 30046
770.995.8000 | Brian.Wolfe@SGS.COM

Details shown reflect the most commonly used configurations.
 Contact AWM for additional details and/or assistance.

02/26/19

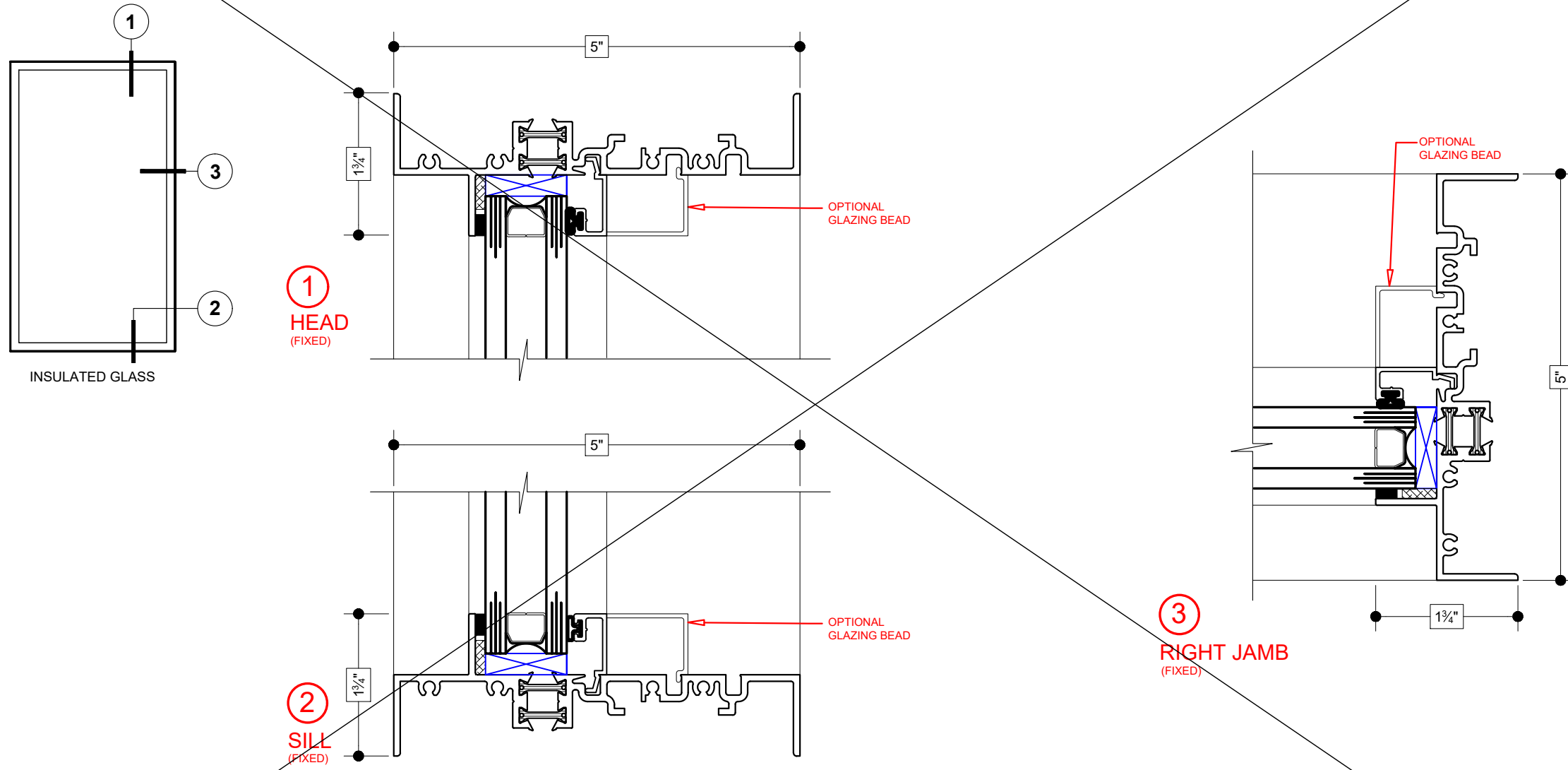

EXAMPLE DETAILS: CONTRACTOR TO PROVIDE SHOP DRAWINGS
 w/ ATTACHMENT DETAILS FROM APPROVED MANUFACTURER

NOT TO SCALE

359 Veterans Blvd., Rutherford, New Jersey 07070

www.architecturalwindow.com

Tel: (201) 939-2200 Fax: (201) 939-2201

PAGE 1 OF 6

TEC SERVICES
 Testing • Engineering • Consulting

SGS

SGS NORTH AMERICA, INC (SGS TEC SERVICES)
 235 BUFORD DR, LAWRENCEVILLE, GA 30046
 770.995.8000 | Brian.Wolfe@SGS.COM

REVISIONS		
No.	DESCRIPTION	DATE
0	90% SET FOR BID	03-NOV-23



J. LLOYD
 ENGINEERING
 P.O. Box 169, Watkinsville, GA 30677
 404.518.6121 | JRL@Lloyd-Eng.com

PROJECT: **SHALLOWFORD ANNEX MASONRY & WATERPROOFING RESTORATION**
 4470 N Shallowford Rd, Atlanta, GA
 CITY OF DUNWOODY PARKS DEPT.

SHEET DESCRIPTION: SECTIONS/DETAILS

PROJECT No.: SGS22131
 JLE22606
 DRAWN BY: JRL
 CHECK BY: JRL
 DATE: 03-NOV-23

SHEET No.
R16

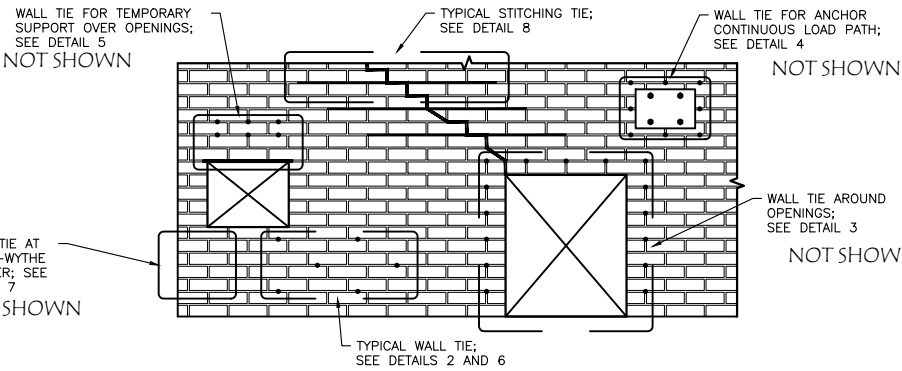

SIMPSON STRONG-TIE HELI-TIE APPLICATIONS

1

NOTES:
1. REFER TO DETAIL 2/HT-1 FOR ADDITIONAL HORIZONTAL SPACING INFORMATION.
2. REFER TO DETAIL 6 OR 9 FOR ADDITIONAL DIMENSIONS.

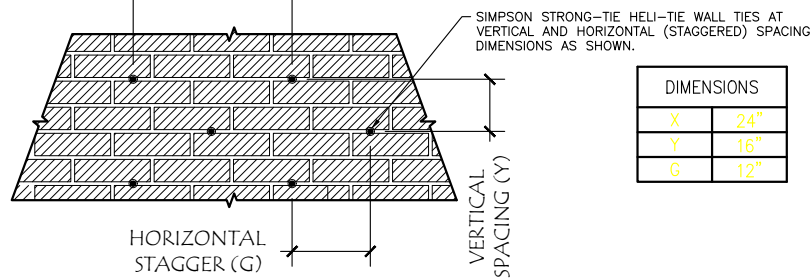

TYPICAL WALL TIE APPLICATION ELEVATION

2

NOTES:
1. REFER TO DETAIL 3/HT-1 FOR ADDITIONAL INSTALLATION INFORMATION.
2. TO ACCOMMODATE WALL CORNER CONDITIONS, HELI-TIE STITCHING TIE MAY BE BENT 90 DEGREES WITH A MIN. BEND RADIUS OF 1/4" 1/4" DEEP GROOVE MADE WITH GRINDER

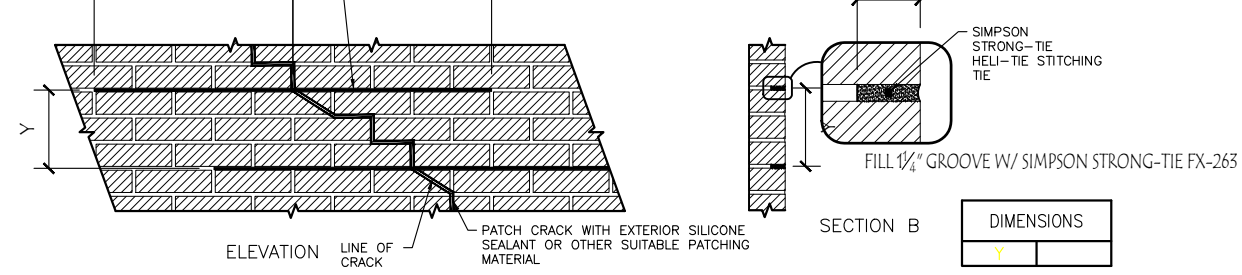

TYPICAL STITCHING TIE APPLICATION

8

HELI-TIE™ HELICAL WALL TIE

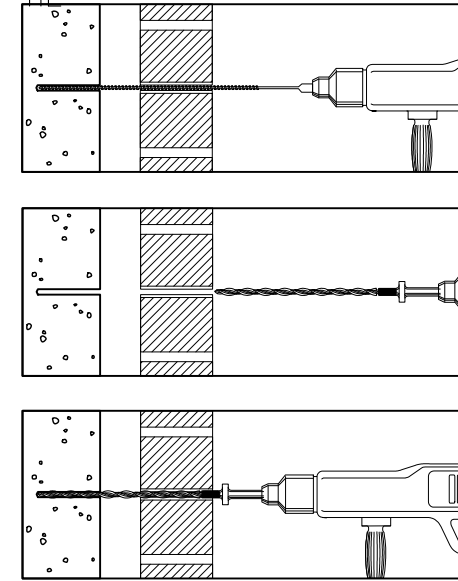

Drill pilot hole through the façade material and into the backup material to the specified embedment depth + 1" using appropriate drill bit(s) in the chart below. Drill should be in rotation-only mode when drilling into soft masonry or into hollow backing material.

Position blue end of the Heli-Tie fastener in the installation tool and insert the unpainted end into the pilot hole.

With the SDS-plus rotohammer in hammer mode, drive the tie until the tip of the installation tool enters the exterior surface of the masonry and countersinks the tie below the surface. Patch the hole in the façade with a matching masonry mortar

SIZE (IN.)	MODEL NO.	DRILL BIT DIAMETER (IN.)
3/8" x 7"	HELI37700A	* USE 7/32" DIA. DRILL BIT UNLESS NOTED OTHERWISE
3/8" x 8"	HELI37800A	
3/8" x 9"	HELI37900A	
3/8" x 10"	HELI371000A	
3/8" x 11"	HELI371100A	
3/8" x 12"	HELI371200A	
3/8" x 14"	HELI371400A	
3/8" x 16"	HELI371600A	
3/8" x 18"	HELI371800A	
3/8" x 20"	HELI372000A	

HELI-TIE™ HELICAL WALL TIE INSTALLATION NOTES

HELI-TIE™ HELICAL STITCHING TIE

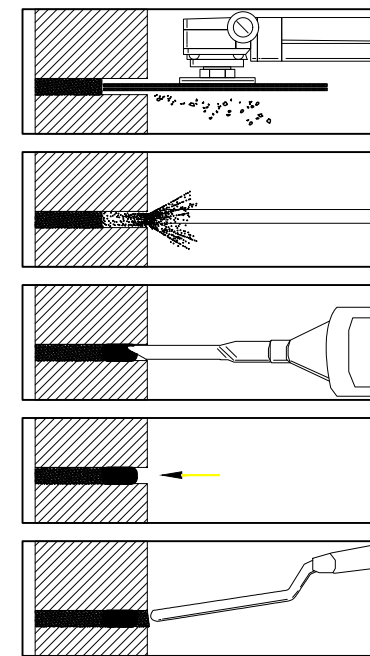

Chase bed joint 20" min. on either side of the affected area to a depth of approximately 1 1/4" with a rotary grinding wheel. Vertical spacing of installation sites should be 12" for brick or every other course for concrete masonry units.

Clear bed joint of all loose debris using water or oil-free compressed air.

Mix non-shrink repair grout or mortar per product instructions and place into the prepared bed joint, filling the void to approximately two-thirds of its depth. Simpson Strong-Tie FX-263 repair mortar should be used.

Embed the tie at one-half the depth of the void.

Trowel displaced grout to fully encapsulate the tie. Fill any remaining voids and vertical cracks with non-shrink repair grout or other repair mortar to conceal repair site.

HELI-TIE™ HELICAL STITCHING TIE INSTALLATION NOTES

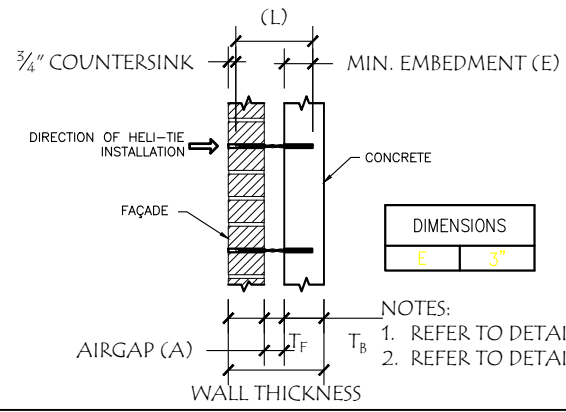

BACKUP: CMU OR CONCRETE

REVISIONS

No.	DESCRIPTION	DATE
0	90% SET FOR BID	03-NOV-23



PROJECT: **SHALLOWFORD ANNEX MASONRY & WATERPROOFING RESTORATION**
4470 N Shallowford Rd, Atlanta, GA
CITY OF DUNWOODY PARKS DEPT.
SHEET DESCRIPTION: SECTIONS/DETAILS

PROJECT No.:	SGS22131
DRAWN BY:	JLE22606
CHECK BY:	JRL
DATE:	03-NOV-23

SHEET No.
R17



COMPANY NAME: _____

Bid Schedule – 2024 Maintenance Repairs Shallowford Annex Building

Pay Item	Pay Item Description	UNIT	QTY	LUMP SUM PRICE Total
0	PRICE FOR BID ACCESS REQUIREMENTS: LUMP SUM SHALL INCLUDE ALL RENTAL EQUIPMENT/APPARATUS FOR THE DURATION OF WORK, MAINTENANCE, PERAIR OF DAMAGED EXISTING ELEMENTS (I.E. WINDOWS NOT BEING REPLACED, MEP EQUIPMENT THAT WAS TO REMAIN, GROUNDS, ETC.) DUE TO CONTRACTOR ERROR, SAFETY REQUIREMENTS DURING USE, AND ANY SIGNANGE REQUIRED FOR ENTRANCE/EXIT EGRESS	LS	LUMP	

COMPANY NAME: _____

The Bid Items provided for in the Bid Schedule are intended to be the only pay items under which the Contractor will be compensated for work described above. The Contractor shall examine the requirements of the work and the pay items in the Bid Schedule and include in the unit prices submitted all labor, equipment, materials, appurtenances, overhead, profit, vehicles, and all other things incidental for the completion of the work as specified.

Work is to commence no later than 10 days after issuance of the Notice to Proceed. The City of Dunwoody requires pricing to remain firm for the duration of the contract. Failure to hold firm pricing for the term of the contract will be sufficient cause for the City to declare bid non-responsive.

Certification of Non-Collusion in Quote Preparation _____
Signature Date

Termination for Cause: The City may terminate this agreement for cause upon ten days prior written notice to the contractor of the contractor's default in the performance of any term of this agreement. Such termination shall be without prejudice to any of the City's rights or remedies by law.

Termination for Convenience: The City may terminate this agreement for its convenience at any time upon 30 days written notice to the contractor. In the event of the City's termination of this agreement for convenience, the contractor will be paid for those services actually performed. Partially completed performance of the agreement will be compensated based upon a signed statement of completion to be submitted by the contractor, which shall itemize each element of performance.

Termination for fund appropriation: The City may unilaterally terminate this Agreement due to a lack of funding at any time by written notice to the Consultant. In the event of the City's termination of this Agreement for fund appropriation, the Consultant will be paid for those services actually performed. Partially completed performance of the Agreement will be compensated based upon a signed statement of completion to be submitted by the Service Provider which shall itemize each element of performance.

Acknowledgement is hereby made of the following Addendum(s) received since issuance of the Contract Documents (identified by number)

Addendum No.	Date			
_____	_____	_____	_____	_____
_____	_____	_____	_____	_____
_____	_____	_____	_____	_____

In compliance with the attached specifications, the undersigned offers and agrees, within ninety (90) days of the date of quote opening, to furnish any or all of the items upon which prices are quoted, at the price set opposite each item, delivered to the designated point(s) within the time specified in the quote schedule.



4800 Ashford Dunwoody Road
Dunwoody, Georgia 30338
dunwoodyga.gov | 678.382.6700

Legal Business Name _____

Federal Tax ID _____

Address _____

Does your company currently have a location within the City of Dunwoody? Yes = No

Representative Signature _____

Printed Name _____

Telephone Number _____

Fax Number _____

Email Address _____



SAMPLE

Solicitation No. _____

CONTRACTOR AFFIDAVIT AND AGREEMENT

By executing this affidavit, the undersigned contractor verifies its compliance with O.C.G.A. 13-10-91, stating affirmatively that the individual, firm, or corporation which is contracting with the City of Dunwoody has registered with and is participating in a federal work authorization program* [any of the electronic verification of work authorization programs operated by the United States Department of Homeland Security or any equivalent federal work authorization program operated by the United States Department of Homeland Security to verify information of newly hired employees, pursuant to the Immigration Reform and Control Act of 1986 (IRCA), P.L. 99-603], in accordance with the applicability provisions and deadlines established in O.C.G.A 13-10-91.

The undersigned further agrees that, should it employ or contract with any subcontractor(s) in connection with the physical performance of services pursuant to this contract, contractor will secure from such subcontractor(s) similar verification of compliance with O.C.G.A 13-10-91 on the Subcontractor Affidavit provided in Rule 300-10-01-.08 or a substantially similar form. Contractor further agrees to maintain records of such compliance and provide a copy of each such verification to the City of Dunwoody at the time the subcontractor(s) is retained to perform such service.

E-Verify * User Identification Number

Company Name

BY: Authorized Officer or Agent Date
(Contractor Signature)

Title of Authorized Officer or Agent of Contractor

Printed Name of Authorized Officer or Agent

SUBSCRIBED AND SWORN
BEFORE ME ON THIS THE

_____ DAY OF _____, 200__

Notary Public

My Commission Expires:

* As of the effective date of O.C.G.A. 13-10-91, the applicable federal work authorization program is "E-Verify" operated by the U.S. Citizenship and Immigration Services Bureau of the U.S. Department of Homeland Security, in conjunction with the Social Security Administration (SSA).



SAMPLE
Affidavit Verifying Status
For City Public Benefit Application

By executing this affidavit under oath, as an applicant for a City of Dunwoody, Georgia Business License or Occupation Tax Certificate, Alcohol License, Taxi Permit or other public benefit as referenced in O.C.G.A. Section 50-36-1, I am stating the following with respect to my application for a City of Dunwoody, Business License or Georgia Occupational Tax Certificate, Alcohol License, Taxi Permit or other public benefit (circle one) for _____.
[Name of natural person applying on behalf of individual, business, corporation, partnership, or other private entity]

1) _____ I am a United States citizen

OR

2) _____ I am a legal permanent resident 18 years of age or older or I am an otherwise qualified alien or non-immigrant under the Federal Immigration and Nationality Act 18 years of age or older and lawfully present in the United States.*

In making the above representation under oath, I understand that any person who knowingly and willfully makes a false, fictitious, or fraudulent statement or representation in an affidavit shall be guilty of a violation of Code Section 16-10-20 of the Official Code of Georgia.

Signature of Applicant:

Date

Printed Name:

SUBSCRIBED AND SWORN

BEFORE ME ON THIS THE

____ DAY OF _____, 20____

*

Alien Registration number for non-citizens

Notary Public

My Commission Expires:

*Note: O.C.G.A. § 50-36-1(e)(2) requires that aliens under the federal Immigration and Nationality Act, Title 8 U.S.C., as amended, provide their alien registration number. Because legal permanent residents are included in the federal definition of “alien”, legal permanent residents must also provide their alien registration number. Qualified aliens that do not have an alien registration number may supply another identifying number below:



STATEMENT OF EQUIPMENT

1. Pursuant to bidding requirements for the work titled:

2023 Maintenance Repairs Shallowford Annex Building

2. Showing Machinery and Other Equipment Available to Contractor for Prosecuting the Work Included in Contract.

Available Machinery and Other Equipment Kind – Size – Capacity	Location	Owned/ Rented	Date Proposed to be placed on Work
_____	_____	_____	_____
_____	_____	_____	_____
_____	_____	_____	_____
_____	_____	_____	_____
_____	_____	_____	_____
_____	_____	_____	_____

A complete list of equipment owned by Contractor may be attached to this statement.

The above is a true statement of the equipment available to the undersigned bidder for prosecuting the work included in the contract.

Signed: _____

Name: _____ (print)

Title: _____

*****ATTENTION*****

IN ORDER FOR CONTRACTOR BID PACKAGE TO BE CONSIDERED RESPONSIVE, THE FOLLOWING FORMS AND INFORMATION MUST BE COMPLETED AND SUBMITTED WITH THE PROPOSAL:

1. USE THE CITY BID SCHEDULE AND FORWARD WITH THE SEALED PROPOSAL FORM.

2. RETURN APPLICABLE COMPLIANCE SHEETS/
SPECIFICATION SHEETS.

3. ACKNOWLEDGE APPLICABLE ADDENDA.

4. STATEMENT OF EQUIPMENT

FAILURE TO RETURN THE ABOVE DOCUMENTS MAY RESULT IN BID BEING DEEMED NON-RESPONSIVE AND AUTOMATIC REJECTION
THE CITY SHALL BE THE SOLE DETERMINANT OF TECHNICALITY VS.
NON-RESPONSIVE BID.

**CITY OF DUNWOODY
DEPARTMENT OF FINANCE AND ADMINISTRATION – PURCHASING DIVISION
GENERAL INSTRUCTIONS FOR BIDDERS**

These Instructions will apply unless a particular item is specifically addressed in the solicitation document or not relevant to the particular type of good or service.

1. PREPARATION OF BIDS:

- A. Each bidder shall examine the drawings, specifications, schedule and all instructions. Failure to do so will be at the bidder's risk, as the bidder will be held accountable for their bid response.
- B. Each bidder shall furnish all information required by the bid form or document. Each bidder shall sign the bid and print or type his or her name on the schedule. The person signing the bid must initial erasures or other changes. An authorized agent of the company must sign bids.
- C. Individuals, firms and businesses seeking an award of a City of Dunwoody contract may not initiate or continue any verbal or written communications regarding a solicitation with any City officer, elected official, employee or other City representative without the permission of Purchasing between the date of the issuance of the solicitation and the date of the final contract award. Violations will be reviewed by the Purchasing Manager. If determined that such communication has compromised the competitive process, the offer submitted by the individual, firm or business may be disqualified from consideration for award.

2. DELIVERY:

- A. Each bidder should state time of proposed delivery of goods or services.
- B. Words such as "immediate," "as soon as possible," etc. shall not be used. The known earliest date or the minimum number of calendar days required after receipt of order (delivery A.R.O.) shall be stated (if calendar days are used, include Saturday, Sunday and holidays in the number).

3. EXPLANATION TO BIDDERS:

Any explanation desired by a bidder regarding the meaning or interpretation of the invitation for bids, drawings, specifications, etc. must be requested by the question cutoff deadline stated in the solicitation in order for a reply to reach all bidders before the close of bid. Any information given to a prospective bidder concerning an invitation for bid will be furnished to all prospective bidders as an addendum to the invitation if such information is necessary or if the lack of such information would be prejudicial to uninformed bidders. The written bid documents supersede any verbal or written communications between parties. Receipt of addendum should be acknowledged in the bid. Although Purchasing will make every effort to send any addendum to known bidders, it is the bidder's ultimate responsibility to ensure that they have all applicable addenda prior to bid submittal. This may be accomplished via contact with Purchasing prior to bid submittal.

4. SUBMISSION OF BIDS:

- A. Bids shall be enclosed in sealed envelopes, addressed to the City of Dunwoody Purchasing Office with the name of the bidder, the date and hour of opening and the invitation to bid number on the face of the envelope. Telegraphic/faxed bids will not be considered. Any addenda should be enclosed in the sealed envelopes as well.
- B. ADD/DEDUCT: Add or deduct amounts indicated on the outside of the envelope are allowed and will be applied to the lump sum amount. Amount shall be clearly stated and should be initialed by an authorized company representative.
- C. Samples of items, when required, must be submitted within the time specified and, unless otherwise specified by the City, at no expense to the City. Unless otherwise specified, samples will be returned at the bidder's request and expense if items are not destroyed by testing.
- D. Items offered must meet required specifications and must be of a quality, which will adequately serve the use and purpose for which intended.
- E. Full identification of each item bid upon, including brand name, model, catalog number, etc. must be furnished to identify exactly what the bidder is offering. Manufacturer's literature may be furnished.

- F. The bidder must certify that items to be furnished are new and that the quality has not deteriorated so as to impair its usefulness.
- G. Unsigned bids will not be considered except in cases where bid is enclosed with other documents, which have been signed. The City will determine this.
- H. The City of Dunwoody is exempt from federal excise tax and Georgia sales tax with regard to goods and services purchased directly by the City. Suppliers and contractors are responsible for federal excise tax and sales tax, including taxes for materials incorporated in City construction projects. Suppliers and contractors should contact the State of Georgia Sales Tax Division for additional information.
- I. Information submitted by a bidder in the bidding process shall be subject to disclosure after the public opening in accordance with the Georgia Open Records Act. Each page of proprietary information must be identified. Entire bid may not be deemed proprietary.

5. WITHDRAWAL OF BID DUE TO ERRORS:

- A. The bidder shall give notice in writing of his claim of right to withdraw his bid without penalty due to an error within two (2) business days after the conclusion of the bid opening procedure. Bids may be withdrawn from consideration if the price was substantially lower than the other bids due solely to a mistake therein, provided the bid was submitted in good faith, and the mistake was a clerical mistake as opposed to a judgment mistake, and was actually due to an unintentional arithmetic error or an unintentional omission of a quantity of work, labor or material made directly in the compilation of the bid, which unintentional arithmetic error or unintentional omission can be clearly shown by objective evidence drawn from inspection of original work papers, documents and material used in the preparation of the bid sought to be withdrawn. The bidder's original work papers shall be the sole acceptable evidence of error and mistake if he elects to withdraw his bid. If a bid is withdrawn under the authority of this provision, the lowest remaining responsive bid shall be deemed to be low bid.
- B. No bidder who is permitted to withdraw a bid shall, for compensation, supply any material or labor or perform any subcontract or other work agreement for the person or firm to whom the contract is awarded or otherwise benefit, directly or indirectly, from the performance of the project for which the withdrawn bid was submitted.
- C. Supplier has up to forty-eight (48) hours to notify Purchasing of an obvious clerical error made in calculation of bid in order to withdraw a bid after bid opening. Withdrawal of bid for this reason must be done in writing within the forty-eight (48) hour period. Suppliers who fail to request withdrawal of bid by the required forty-eight (48) hours shall automatically forfeit bid bond. Bid may not be withdrawn otherwise.
- D. Bid withdrawal is not automatically granted and will be allowed solely at the City of Dunwoody's discretion.

6. TESTING AND INSPECTION:

Since tests may require several days for completion, the City reserves the right to use a portion of any supplies before the results of the tests are determined. Cost of inspections and tests of any item, which fails to meet the specifications, shall be borne by the bidder.

7. F.O.B. POINT:

Unless otherwise stated in the invitation to bid and any resulting contract, or unless qualified by the bidder, items shall be shipped F.O.B. Destination. The seller shall retain title for the risk of transportation, including the filing for loss or damages. The invoice covering the items is not payable until items are delivered and the contract of carriage has been completed. Unless the F.O.B. clause states otherwise, the seller assumes transportation and related charges either by payment or allowance.

8. PATENT INDEMNITY:

The contractor guarantees to hold the City, its agents, officers or employees harmless from liability of any nature or kind for use of any copyrighted or un-copyrighted composition, secret process, patented or unpatented invention, articles or appliances furnished or used in the performance of the contract, for which the contractor is not the patentee, assignee or licensee.

9. BID BONDS AND PAYMENT AND PERFORMANCE BONDS (IF REQUIRED):

A five percent (5%) bid bond, a one hundred percent (100%) performance bond, and a one hundred percent (100%) payment bond shall be furnished to the City of Dunwoody for any bid as required in bid package or document. Failure to submit appropriate bonding will result in automatic rejection of bid. Bonding company must be authorized to do business in Georgia by the Georgia Insurance Commission, listed in the Department of the Treasury's publication of companies holding certificates of authority as acceptable surety on Federal bonds and as acceptable reinsuring companies, and have an A.M. Best rating as stated in the insurance requirement of the solicitation.

10. DISCOUNTS:

In connection with any discount offered, time will be computed from the date of delivery and acceptance at destination or from the date correct invoice or voucher is received, whichever is the later date. Payment is deemed to be made for the purpose of earning the discount, on the date of the City check.

11. AWARD:

- A. Award will be made to the lowest responsive and responsible bidder. The quality of the articles to be supplied, their conformity with the specifications, their suitability to the requirements of the City, and the delivery terms will be taken into consideration in making the award. The City may make such investigations as it deems necessary to determine the ability of the bidder to perform, and the bidder shall furnish to the City all such information and data for this purpose as the City may request. The City reserves the right to reject any bid if the evidence submitted by, or investigation of such bidder fails to satisfy the City that such bidder is properly qualified to carry out the obligations of the contract.
- B. The City reserves the right to reject or accept any or all bids and to waive technicalities, informalities and minor irregularities in bids received.
- C. The City reserves the right to make an award as deemed in its best interest, which may include awarding a bid to a single bidder or multiple bidders; or to award the whole bid, only part of the bid, or none of the bid to single or multiple bidders, based on its sole discretion of its best interest.

12. DELIVERY FAILURES:

Failure of a contractor to deliver within the time specified or within reasonable time as interpreted by the Purchasing Manager, or failure to make replacement of rejected articles/services when so requested, immediately or as directed by the Purchasing Manager, shall constitute authority for the Purchasing Manager to purchase in the open market articles/services of comparable grade to replace the articles/services rejected or not delivered. On all such purchases, the contractor shall reimburse the City within a reasonable time specified by the Purchasing Manager for any expense incurred in excess of contract prices, or the City shall have the right to deduct such amount from monies owed the defaulting contractor. Alternatively, the City may penalize the contractor one percent (1%) per day for a period of up to ten (10) days for each day that delivery or replacement is late. Should public necessity demand it, the City reserves the right to use or consume articles delivered which are substandard in quality, subject to an adjustment in price to be determined by the Purchasing Manager.

13. CITY FURNISHED PROPERTY:

No material, labor or facilities will be furnished by the City unless so provided in the invitation to bid.

14. REJECTION AND WITHDRAWAL OF BIDS:

Failure to observe any of the instructions or conditions in this invitation to bid may constitute grounds for rejection of bid.

15. CONTRACT:

- A. Each bid is received with the understanding that the acceptance in writing by the City of the offer to furnish any or all of the commodities or services described therein shall constitute a contract between the bidder and the City which shall bind the bidder on his part to furnish and deliver the articles quoted at the prices stated in accordance with the conditions of said accepted bid. The City, on its part, may order from such contractor, except for cause beyond reasonable control, and to pay for, at the agreed prices, all articles specified and delivered.
- B. It is understood that the bidder has reviewed the contract documents with the understanding that the City of Dunwoody requires that all agreements between the parties must be entered into via this document. If any

exceptions are taken to any part, each must be stated in detail and submitted as part of the bid. If no exceptions are stated, it is assumed that the bidder fully agrees to the provisions contained in the "Sample Contract" in its entirety.

- C. When the contractor has performed in accordance with the provisions of this agreement, the City of Dunwoody shall pay to the contractor, within thirty (30) days of receipt of any department approved payment request and based upon work completed or service provided pursuant to the contract, the sum so requested, less the retainage stated in this agreement, if any.

16. NON-COLLUSION:

Bidder declares that the bid is not made in connection with any other bidder submitting a bid for the same commodity or commodities, and that the bid is bona fide and is in all respects fair and without collusion or fraud. An affidavit of non-collusion shall be executed by each bidder. Collusion and fraud in bid preparation shall be reported to the State of Georgia Attorney General and the United States Justice Department.

17. DEFAULT:

The contract may be canceled or annulled by the Purchasing Manager in whole or in part by written notice of default to the contractor upon non-performance or violation of contract terms. An award may be made to the next low responsive and responsible bidder, or articles specified may be purchased on the open market similar to those so terminated. In either event, the defaulting contractor (or his surety) shall be liable to the City for costs to the City in excess of the defaulted contract prices; provided, however, that the contractor shall continue the performance of this contract to the extent not terminated under the provisions of this clause. Failure of the contractor to deliver materials or services within the time stipulated on his bid, unless extended in writing by the Purchasing Manager, shall constitute contract default.

18. TERMINATION FOR CAUSE:

The City may terminate this agreement for cause upon ten days prior written notice to the contractor of the contractor's default in the performance of any term of this agreement. Such termination shall be without prejudice to any of the City's rights or remedies by law.

19. TERMINATION FOR CONVENIENCE:

The City may terminate this agreement for its convenience at any time upon 30 days written notice to the contractor. In the event of the City's termination of this agreement for convenience, the contractor will be paid for those services actually performed. Partially completed performance of the agreement will be compensated based upon a signed statement of completion to be submitted by the contractor, which shall itemize each element of performance.

20. DISPUTES:

Except as otherwise provided in the contract documents, any dispute concerning a question of fact arising under the contract which is not disposed of shall be decided after a hearing by the Purchasing Manager, who shall reduce his/her decision to writing and mail or otherwise furnish a copy thereof to the contractor. The decision of the Purchasing Manager shall be final and binding; however, the contractor shall have the right to appeal said decision to a court of competent jurisdiction.

21. SUBSTITUTIONS:

Bidders offering and quoting on substitutions or who are deviating from the attached specifications shall list such deviations on a separate sheet to be submitted with their bid. The absence of such a substitution list shall indicate that the bidder has taken no exception to the specifications contained herein.

22. INELIGIBLE BIDDERS:

The City may choose not to accept the bid of a bidder who is in default on the payment of taxes, licenses or other monies due to the City. Failure to respond to three (3) consecutive times for any given commodity/service may result in removal from the supplier list under that commodity/service.

23. BUSINESS LICENSE:

Each successful bidder shall provide evidence of a valid City of Dunwoody business license if the bidder maintains an office within the City of Dunwoody. Unincorporated, out of City, and out of State bidders are required to provide evidence of a certificate to do business in any town, County or municipality in the State of Georgia, or as otherwise required by City ordinance or resolution.

24. ALTERATIONS OF SOLICITATION AND ASSOCIATED DOCUMENTS:

Alterations of City documents are strictly prohibited and will result in automatic disqualification of the firm's solicitation response. If there are "exceptions" or comments to any of the solicitation requirements or other language, then the firm may make notes to those areas, but may not materially alter any document language.

25. TAX LIABILITY:

Local and state governmental entities must notify contractors of their use tax liability on public works projects. Under Georgia law, private contractors are responsible for paying a use tax equal to the sales tax rate on material and equipment purchased under a governmental exemption that is incorporated into a government construction project: excluding material and equipment provided for the installation, repair, or expansion of a public water, gas or sewer system when the property is installed for general distribution purposes. To the extent the tangible personal property maintains its character (for example the installation of a kitchen stove), it remains tax-exempt. However, if the installation incorporates the tangible personal property into realty, e.g., the installation of sheetrock, it becomes taxable to the private contractor. See O.C.G.A. 48-8-3(2) and O.C.G.A. 48-8-63

26. GENERAL CONTRACTORS LICENSE:

All General Contractors must have a current valid license from the State Licensing Board for Residential and General Contractors, unless specifically exempted from holding such license pursuant to Georgia law (O.C.G.A. Section 43-41-17).

27. INDEMNIFICATION:

To the fullest extent permitted by law, the Contractor shall, at his sole cost and expense, indemnify, defend, satisfy all judgments, and hold harmless the City, the engineer, and their agents and employees from and against all claims, damages, actions, judgments, costs, penalties, liabilities, losses and expenses, including, but not limited to, attorney's fees arising out of or resulting from the performance of the work, provided that any such claim, damage, action, judgment, cost, penalty, liability, loss or expense (1) is attributable to bodily injury, sickness, disease, or death, or to injury to or destruction of tangible property (other than the work itself) including the loss of use resulting therefrom, and (2) is caused in whole or in part by any act or omission of the Contractor, any subcontractor, anyone directly or indirectly employed by any of them or anyone for whose acts any of them may be liable, regardless whether such claim is caused in part by a party indemnified hereunder. Such obligation shall not be construed to negate, abridge or otherwise reduce any of the rights or obligations of indemnity which would otherwise exist as to any party or person described in this agreement. In any and all claims against the City, the engineer, or any of their agents or employees by any employee of the Contractor, any subcontractor, anyone directly or indirectly employed by any of them, or anyone for whose acts any of them may be liable, the indemnification obligation contained herein shall not be limited in any way by any limitation on the amount or type of damages, compensation, or benefits payable by or for the Contractor or any subcontractor under Worker's Compensation Acts, disability benefit acts, or other employee benefit acts.

28. ENVIRONMENTAL SUSTAINABILITY

The City of Dunwoody is committed to environmental sustainability. The City believes we have a unique opportunity to further expand our leadership in the area of environmentally preferable purchasing, and through our actions, elicit changes in the marketplace. By further incorporating environmental considerations into public purchasing, the City of Dunwoody will positively impact human health and the environment, remove unnecessary hazards from its operations, reduce costs and liabilities, and improve the environmental quality of the region. As such the City encourages the incorporation of environmental sustainability into proposals.

DIRECTIONS TO DUNWOODY CITY HALL

From I-285 take Exit 29 (Ashford-Dunwoody Rd.) and turn north. At the 6th intersection (Ashford Dunwoody Road & Valley View Road), make a left at the light and you will turn right into the City Hall parking lot.

APPENDIX A
SAMPLE CONTRACT AND GENERAL CONDITIONS
DO NOT SIGN CONTRACT. DO NOT SUBMIT WITH BID.

CONTRACT

This **CONTRACT** made and entered into this _____ day of _____, 20____ by and between Dunwoody, Georgia (Party of the First Part, hereinafter called the City), and _____, (Party of the Second Part, hereinafter called the Contractor).

WITNESSETH: That the said Contractor has agreed, and by these presents does agree with the said City, for the consideration herein mentioned and under the provision of the Performance Bond and Payment Bond required by the Specifications to furnish all equipment, tools, materials, skill and labor of every description necessary to carry out and complete in a good, firm and substantial and workmanlike manner, the work specified, in strict conformity with the drawings and specifications, together with the foregoing proposal made by the Contractor, the Advertisement, the Instructions to Bidders, General Conditions, and this Contract, shall all form essential parts to this Contract. The work covered by this Contract includes all work shown on plans and specifications and listed in the conditions and specifications to wit:

(Description)

The Contractor awarded work under this contract shall commence work within ten (10) days after the issuance of the Notice to Proceed and shall fully complete all work hereunder within Consecutive calendar days from and after said date.

If said work is not completed within the time stated, the Contractor shall be liable and hereby agrees to pay the City as liquidated damages and not as a penalty, the amount of _____ Dollars and no/100 dollars (\$ _____) per day as liquidation of the extra expense incurred by the City and liquidated damages to the City.

The City shall pay and the Contractor shall receive the prices stipulated in the proposal hereto attached as full compensation for everything furnished and done by the Contractor under this contract, which shall in no event exceed (\$ _____) based on the proposal which sum shall be paid in the manner and terms specified in the Contract Documents, but before issuance of certificate of payment, if the Contractor shall not have submitted evidence satisfactory to the City that all payrolls, materials bills, and other indebtedness connected with the work have been paid, the City may withhold, in addition to the retained percentages, such amount or amounts as may be necessary to pay just claims for labor and services rendered and materials in and about the work, and such amount or amounts withheld or retained may be applied by the City to the payment of such just claims.

When the Contractor has performed in accordance with the provisions of this Contract, City shall pay to the Contractor, within thirty (30) days of receipt of any payment request based upon work completed or service provided pursuant to the Contract, the sum so requested, less the retainage stated in this Contract, if any. In the event that the City fails to pay the Contractor within sixty (60) days of receipt of a pay request based upon work completed or service provided pursuant to the Contract, the City shall pay the Contractor interest at the rate of 1/2% per month or pro rata fraction thereof, beginning the sixty-first (61st) day following receipt of the pay request. The Contractor's acceptance of progress payments or final payment shall release all claims for interest on said payments.

It is further mutually agreed between the Parties hereto that if, at any time after the execution of the Contract and the Performance Bond for its faithful performance and the Payment Bond, the first party shall deem the surety or sureties upon such bond to be inadequate to cover the performance of the work, the second party shall, at its expense, within five (5) days after the receipt of notice from the first party to do so, furnish an additional bond or bonds in such form and amount, and with such surety or sureties as shall be satisfactory to the first party. In such event, no further payment to the second party shall be deemed to be due under this Contract until such new or additional security for the faithful performance of the work shall be furnished in a manner and form satisfactory to the first party.

The parties agree that each of the provisions included in this Contract is separate, distinct and severable from the other and remaining provisions of this Contract, and that the invalidity of any Contract provision shall not affect the validity of any other provision or provisions of this Contract.

(Signatures Next Page)



4800 Ashford Dunwoody Road
Dunwoody, Georgia 30338
dunwoodyga.gov | 678.382.6700

IN WITNESS WHEREOF, the parties hereto, acting through their duly authorized agents, have caused this **CONTRACT** to be signed, sealed and delivered.

CITY OF DUNWOODY, GEORGIA

By: _____

Lynn P. Deutsch, Mayor
City of Dunwoody, Georgia

ATTEST:

Signature

Print Name
City Clerk/ City of Dunwoody

APPROVED AS TO FORM:

Signature
City of Dunwoody Staff Attorney

SERVICE PROVIDER: _____

BY: _____

Signature

Print Name

Title

ATTEST:

Signature

Print Name
Corporate Secretary
(Seal)

GENERAL CONDITIONS

These General Conditions will apply unless a particular item is specifically addressed in the solicitation documents

1. SCOPE OF WORK

The Contract will be to provide to the City in accordance with the Contract Documents. All work shall be performed in accordance with the Specifications attached hereto.

2. REGULATIONS

- 2.1 The Contractor shall comply with all applicable federal, state and local laws, ordinances, rules and regulations pertaining to the performance of the work specified herein.
- 2.2 The Contractor shall obtain all permits, licenses and certificates, or any such approvals of plans or specifications as may be required by Federal, State and local laws, ordinances, rules and regulations, for the proper execution of the work specified herein.
- 2.3 During the performance of this Contract, the Contractor shall keep current and, if requested by the City, provide copies of any and all licenses, registrations or permits required by applicable governing agencies. The Contractor shall keep a copy of any and all licenses, registrations and permits on the job site while performing the Contract work.

3. WORK HOURS

- 3.1 Unless otherwise noted in the Bid Documents, the Contractor shall normally perform on-site work during Standard Work Hours which are between 7:30 a.m. and 8:00 p.m., Monday through Friday, excluding City's observed holidays. The City may require the Contractor to perform work on the city's premises during Non-standard Work Hours which are outside the Standard Work Hours. Non-standard Work Hours may be arranged with prior written approval of the City. The Contractor shall advise the City no less than 48 hours in advance of its projected work schedule. The Contractor shall perform no work during City observed holidays without the prior written permission of the City.
- 3.2 In the event an emergency condition is declared by the City's Manager or his respective designee, the Contractor will perform work during such hours as requested by the City.
- 3.3 Work can be performed away from the City's premises, but in all cases, such work must be maintained and documented on the City's servers (shared drives accessed via a VPN, etc.)

4. CONTRACTOR'S PERSONNEL

- 4.1 The Contractor will abide by all State and Federal regulations on wages and hours of an employee dealing with the employment relationship between the Contractor and its subsidiaries or related parties and its employees, including but not limited to the Federal National Labor Relations Act, the Federal Fair Labor Standards Act, the Federal Civil Rights Act of 1964, as amended, and the Americans with Disabilities Act.
- 4.2 The Contractor shall require all prospective employees to show proof of citizenship, or proof from the United States Immigration and Naturalization Service of valid entry permits and/or work permits for legal aliens and proof that such legal aliens are eligible to be employed in the United States. This includes any requirement for participation in the DHS e-Verify or SAVE program.
- 4.3 Should the Contractor engage employees who are illiterate in English, it will be the Contractor's responsibility and obligation to train such employees to be able to identify and understand all signs and notices in and/or around the areas that relate to them or the services being performed by them pursuant to this Contract. In addition, the Contractor will have someone in attendance at all times who can communicate instructions to said employee.

- 4.4 The Contractor shall maintain a drug-free workplace within the meaning of the Georgia Drug-free Workplace Act. No employee shall be hired by a Contractor for work on the City's premises prior to such employee having tested negative for drugs. In addition, existing employees of the Contractor must be subject to drug testing by the Contractor upon reasonable suspicion of drug use. Results of all such drug tests are to be retained by the Contractor. Copies shall be provided to the City, if requested.
- 4.5 The Contractor shall transfer promptly from the City any employee or employees that the City advises are not satisfactory, and replace such personnel with employees satisfactory to the City; but in no event shall the City be responsible for monitoring or assessing the suitability of any employee or agent of the Contractor.
- 4.6 The Contractor's employees shall be instructed that no gratuities shall be solicited or accepted for any reason whatsoever from the tenants, customers or other persons at the City. The Contractor shall be responsible for ensuring that all articles found by its employees on the City's premises are turned over to the City or the City's designated agent in charge of such articles.
- 4.7 A valid driver license (Commercial Driver License, if applicable) will be required of all personnel operating motor vehicles or motorized equipment on roadways in or around the City.
- 4.8 While working on city property all Contractors' employees shall wear (when appropriate) neat-appearing business casual attire or uniforms with the company name and/or logo and footwear of a style that complies with all legal and safety requirements, including and without limitation, the requirements of OSHA.
- 4.9 Designation of Project Manager - The Contractor shall designate a Project Manager acceptable to the City for all purposes related to this Specification.
- 4.9.1 The Project Manager shall be fully responsible for the Contractor meeting all of its obligations under this Contract. The Project Manager shall provide the City with an appropriate status report on the progress of the project every week, as well as conduct weekly team status review calls or meeting with the City during the Contract term, the day to be mutually determined as part of the Project Plan. This report may be delivered by facsimile, e-mail, U.S. postal service, or private carrier, provided it is delivered in a timely manner.
- 4.9.2 The Project Manager shall be available, as reasonably required, to be on-site during necessary times. Such times shall be discussed between the Project Manager and the City, but the final required times will be at the City's discretion.
- 4.9.3 In the event that the designated Project Manager terminates employment with the Contractor, or is requested by the City to be removed from the role of Project Manager (as provided in Section 4.5), the position shall be assumed by an individual with equivalent qualifications, experience, and knowledge. Such replacement shall require the City's prior approval.
- 4.9.4 The Contractor shall not replace the approved Project Manager without written approval of the City, which approval will not be unreasonably withheld.
- 4.10 The process by which the implementation partner requests the removal of a team member from the project. If a Contractor replaces a proposed team member, the Contractor shall replace that team member with a new team member of similar experience. The City reserves the right to accept or reject any proposed or replacement team member, with or without cause, at any time during the duration of the project.

5. ITEMS PROVIDED BY THE CITY

- 5.1 Work Location. It shall be the sole responsibility of the Contractor to provide for project team work locations.
- 5.2 Uninterruptible Power Supply (UPS). It shall be the sole responsibility of the Contractor to provide for project team all necessary UPS.

- 5.3 Printers. It shall be the sole responsibility of the Contractor to provide for project team all necessary printers.
- 5.4 Office Space. It shall be the sole responsibility of the Contractor to provide for project team all necessary office space.
- 5.5 Utility Services. It shall be the sole responsibility of the Contractor to provide for project team all necessary utility services.
- 5.6 Employee Parking. It shall be the sole responsibility of the Contractor to provide for project team all necessary parking.

6. TOOLS AND EQUIPMENT

It shall be the sole responsibility of the Contractor to provide for project team all tools, parts and equipment necessary to perform work under this Contract.

7. PERFORMANCE REQUIREMENTS

- 7.1 The Contractor shall perform all of its obligations and functions under the Contract in accordance with the Contract specifications, industry standards and any manufacturers' specifications. The Contractor shall adjust and coordinate its activities to the needs and requirements of the City and perform its activities so as not to annoy, disturb, endanger, unreasonably interfere with or delay the operations or activities of the City.
- 7.2 The Contractor's personnel shall perform work in a neat and professional manner, and in compliance with all Federal, State, and City of Dunwoody regulations and OSHA rules and regulations shall be followed at all times.
- 7.3 Dates for commencement and completion of work shall be coordinated with the City's Authorized Representative.
- 7.4 Any work required beyond that which is specified herein shall be reported in advance to the City. At no time shall work beyond the scope be performed without prior written authorization from the City.
- 7.5 The Contractor shall utilize maximum safety precautions. Tools and equipment will be in a good state of repair, safe to use, and be used in the manner in which they were intended. The Contractor is required to inform all workers and concerned persons of the Material Safety Data on all products being utilized on this project. No materials or equipment will be left unattended or stored on the project site at any time.

8. CONFIDENTIAL INFORMATION

- 8.1 In the course of performing the Contract work, the Contractor may gain access to security-sensitive and other sensitive information of the City.
- 8.2 The Contractor agrees to hold all City data and information in confidence and to make such information known only to its employees and subcontractors who have a legitimate need to know such information and only after advising such persons of the Contractor's non-disclosure obligations.
- 8.3 The Contractor shall seek the City's prior written consent before using for any purpose other than the fulfillment of the Contractor's obligations hereunder, or before releasing, disclosing, or otherwise making such information available to any other person.
- 8.4 The Contractor shall employ such practices and take such actions to protect the City's information from unauthorized use or disclosure as the Contractor employs and takes to protect its own information, but in no event shall the Contractor use less than reasonable efforts to protect the City's information.
- 8.5 The provisions of this Section shall survive the expiration or earlier termination of the Contract.

9. USE OF PREMISES

During the progress of the work specified herein, the Contractor shall keep the premises free from accumulation of waste materials, and other debris resulting from the work. At the completion of each work day, the Contractor shall remove daily all waste materials and debris from, and about the premises as well as tools, equipment, machinery and surplus material, and leave the site clean and ready for occupancy by the City.

10. SAFETY AND PROTECTION

The Contractor shall be solely and completely responsible for initiating, maintaining and supervising all safety precautions and programs in connection with the work. The Contractor shall take all necessary precautions for the safety of, and shall provide the necessary protection to prevent damage, injury or loss to all employees on the work site and other persons including, but not limited to, the general public who may be affected thereby.

11. COMPENSATION - INVOICE AND PAYMENT FOR SERVICES

- 11.1 The City shall pay the Contractor, subject to any authorized deductions, the applicable prices set forth for each service authorized by the City, and actually delivered or performed, as the case may be, by the Contractor to the satisfaction and acceptance, as appropriate, of the City. The timing of such payments shall be as set forth below in this Section.
- 11.2 The City shall pay the Contractor the price as set forth within 30 days after completion of the services, or 30 days after the City's receipt of the invoice, whichever is later. The Contractor shall invoice the City for the implementation services that were completed and accepted under the Contract, accompanied by such supporting documentation and other backup material as the City may reasonably require.
- 11.3 The Contractor shall invoice with such supporting documentation and other backup material as the City may reasonably require.
- 11.4 The Contractor shall deliver to the City for approval and acceptance, and before eligible for final payment of any amounts due, all documents and material prepared by the Contractor for the City under this Contract.
- 11.5 The City shall pay the undisputed amount of the Contractor's invoice, as it may be reduced to reflect unsubstantiated or unsatisfactory services. Items in dispute shall be paid upon the resolution of the dispute. No verification or payment of any amounts invoiced shall preclude the City from recovering any money paid in excess of that due under the terms of this Contract.
- 11.6 The Contractor shall be obligated to pay promptly all proper charges and costs incurred by the Contractor for labor and materials used for the work performed hereunder. The City shall have the right, but not the obligation, to pay directly to third parties (including subcontractors) all past due amounts owed by the Contractor to third parties for labor and materials used for the work hereunder, based on invoices submitted by such third party, and all such amounts paid by the City shall be applied toward, and shall reduce, amounts owed to Contractor hereunder.
- 11.7 The Contractor shall submit all invoices to: City of Dunwoody, GA, Accounts Payable, 41 Perimeter Center East, Suite 250, Dunwoody, GA 30346.

12. COMPLIANCE WITH LAWS AND REGULATIONS

- 12.1 The Contractor shall perform its obligations and functions hereunder in compliance with the applicable laws of the United States, the State of Georgia, DeKalb County, the City of Dunwoody, any applicable rules, regulations or directives of any agency thereof, and the applicable regulations of the City. OSHA rules and regulations shall be followed at all times. The City shall have the right (but not the obligation) to contest or challenge by any means whatsoever any law, regulation, rule or directive which in any way affects or otherwise impacts upon the Contractor's performance of its obligations and functions hereunder; the Contractor shall cooperate to the fullest extent and take whatever action (including becoming a party in any litigation) the City should reasonably request in connection with any such challenge or contest by the City.

- 12.2 The Contractor shall obtain and keep current all licenses, permits and authorizations, whether municipal, county, state or federal, required for the performance of its obligations and functions hereunder and shall pay promptly when due all fees therefor.
- 12.3 The Contractor shall abide by all applicable state and federal regulations pertaining to wages and hours of an employee; including but not limited to the Contractor's compliance with requirements of the Official Code of Georgia Annotated and relevant State Rules and Regulations.

13. CONTRACTOR'S LIABILITY

The Contractor shall be responsible for the prompt payment of any fines imposed on the City or the Contractor by any other federal, state or local governmental agency as a result of the Contractor's, or its subcontractor's (or the officers', directors', employees' or agents' of either), failure to comply with the requirements of any law or any governmental agency rule, regulation, order or permit. The liability of the Contractor under this Section 13 is in addition to and in no way a limitation upon any other liabilities and responsibilities which may be imposed by applicable law or by the indemnification provisions of Section 14 hereof, and such liability shall survive the expiration or earlier termination of this Contract.

14. INDEMNIFICATION AND INSURANCE

- 14.1 The Contractor shall indemnify, defend and hold completely harmless the City, and the members (including, without limitation, members of the City's Council, and members of the citizens' advisory committees of each), officers, employees and agents of each, from and against any and all liabilities (including statutory liability and liability under Workers' Compensation Laws), losses, suits, claims, demands, judgments, fines, damages, costs and expenses (including all costs for investigation and defense thereof, including, but not limited to, court costs, paralegal and expert fees and reasonable attorneys' fees) which may be incurred by, charged to or recovered from any of the foregoing by (i) reason or on account of damage to or destruction or loss of any property of the City, or any property of, injury to or death of any person resulting from or arising out of or in connection with the performance of this Contract, or the acts or omissions of the Contractor's directors, officers, agents, employees, subcontractors, licensees or invitees, regardless of where the damage, destruction, injury or death occurred, unless such liability, loss, suit, claim, demand, judgment, fine, damage, cost or expense was proximately caused solely by the City's negligence or by the joint negligence of the City and any person other than the Contractor or the Contractor's directors, officers, agents, employees, subcontractors, licensees, or invitees, or (ii) arising out of or in connection with the failure of the Contractor to keep, observe or perform any of the covenants or agreements in this Contract which are required to be kept, observed or performed by the Contractor, or (iii) arising out of or in connection with any claim, suit, assessment or judgment prohibited by Section 14.4 below by or in favor of any person described in Section 14.5 below, or (iv) arising out of or in connection with any action by Contractor or its directors, officers, agents, employees, subcontractors, licensees or invitees. The City agrees to give the Contractor reasonable notice of any suit or claim for which indemnification will be sought hereunder, to allow the Contractor or its insurer to compromise and defend the same to the extent of its interests, and to reasonably cooperate with the defense of any such suit or claim. In carrying out its obligations under this section, the Contractor shall engage counsel reasonably acceptable to the City. In any suit, action, proceeding, claim or demand brought in respect of which the City may pursue indemnity, the City shall have the right to retain its own counsel, but the fees and expenses of such counsel shall be at the expense of the City unless (1) the Contractor and the City shall have mutually agreed to the contrary, (2) the Contractor has failed within a reasonable time to retain counsel reasonably satisfactory to the City, or (3) the City and the Contractor are both named parties in any such proceeding and, in the sole judgment of the City, representation of both the City and the Contractor by the same counsel would be inappropriate due to actual or potential differing interests between them. The indemnification provisions of this Section 14 shall survive the expiration or earlier termination of this Contract with respect to any acts or omissions occurring during the term of the Contract.
- 14.2 In addition to indemnification provisions stated above, if the City's use of any service, software, firmware, programming, or other item provided by or on behalf of the Contractor is enjoined due to infringement of another person or entity's intellectual property rights, the Contractor shall promptly, at its sole cost and expense, modify the infringing item so that it no longer infringes, procure for the City the legal right to continue using

the infringing item, or procure for the City a non-infringing item, or procure for the City a non-infringing replacement item having equal or greater functional capabilities as the infringing item.

- 14.3 The Contractor shall assume all responsibility for loss caused by neglect or violation of any state, federal, municipal or agency law, rule, regulation or order. The Contractor shall give to the proper authorities all required notices relating to its performance, obtain all official permits and licenses, and pay all proper fees and taxes. It shall promptly undertake proper monetary restitution with respect to any injury that may occur to any building, structure or utility in consequence of its work. The Contractor will notify the City in writing of any claim made or suit instituted against the Contractor because of its activities in performance of the Contract.
- 14.4 No recourse under or upon any obligation, covenant or agreement contained in this Contract, or any other agreement or document pertaining to the work or services of the Contractor hereunder, as such may from time to time be altered or amended in accordance with the provisions hereof, or any judgment obtained against the City, or by the enforcement of any assessment or by any legal or equitable proceeding by virtue of any statute or otherwise, under or independent of this Contract, shall be had against any member (including, without limitation, members of the City's Council, or members of the citizens advisory committees of each), any officer, employee or agent, as such, past, present, or future of the City, either directly or through the City or otherwise for any claim arising out of or in connection with this Contract or the work or services conducted pursuant to it, or for any sum that may be due and unpaid by the City. Any and all personal liability of every nature, whether at common law or in equity, or by statute or by constitution or otherwise, of any such member, officer, employee, or agent, as such, to respond by reason of any act or omission on his or her part or otherwise for any claim arising out of or in connection with this Contract or the work or services conducted pursuant to it, or for the payment for or to the City, or any receiver therefore or otherwise, of any sum that may remain due and unpaid by the City, is expressly waived and released as a condition of and in consideration of the execution of this Contract and the promises made to the Contractor pursuant to this Contract.
- 14.5 In any and all claims against the City, or any of their officers, members, agents, servants or employees, by any employee of the Contractor, any subcontractor, anyone directly or indirectly employed by any of them or anyone for whose acts any of them may be liable, the indemnification obligation of the Contractor under this Section 14 shall not be limited in any way by any limitation on the amount or type of damages, compensation or benefit payable by or for the Contractor or any subcontractor under Workers' Compensation Acts, disability benefit acts or other employee benefit acts.
- 14.6 No provisions of Section 14 herein shall be construed to negate, abridge, or otherwise reduce any other right of indemnity that the City may have as to any party or person described therein.
- 14.7 Insurance
- 14.7.1 General Liability and Automobile Liability. The Contractor shall purchase and maintain in force during the term of the Contract, at its own cost and expense, to protect the Contractor, the City, and the members (including, without limitation, all members of the governing City's Council and the citizens' advisory committees of each), officers, agents, and employees of each, from and against any and all liabilities arising out of or in connection with the Contractor's performance of the Contract work:
- (1) Commercial general liability insurance with coverage of not less than ONE MILLION DOLLARS (\$1,000,000.00) combined single limit per occurrence, and with contractual liability coverage for Contractor's covenants to and indemnification of the City under the Contract, and
 - (2) Automobile liability insurance with policy limits of not less than ONE MILLION DOLLARS (\$1,000,000.00) combined single limit per accident or occurrence covering each motor vehicle operated on City property.
- 14.7.1.1 Self-Insured Retention. Contractor's commercial general liability insurance policies shall not be subject to a self-insured retention exceeding \$10,000, if the value of the Contract is less than

\$1,000,000, and not be subject to a self-insured retention exceeding \$100,000, if the Contract is \$1,000,000 or more, unless approved by the City Manager. Contractor's automobile liability insurance policies shall not be subject to a self-insured retention exceeding \$10,000, unless approved by the City Manager.

14.7.1.2 Additional Insured Endorsement. Contractor agrees and shall cause the City their members (including, without limitation, members of the City's Council and members of the citizens' advisory committees of each), officers, employees, and agents to be named as additional insured's under such policy or policies of commercial general and automobile liability insurance.

- 14.7.2 Workers' Compensation and Employer's Liability. If Contractor has any employee working on City property, Contractor shall procure and maintain in force during the term of the Contract (i) workers' compensation insurance, and (ii) employer's liability insurance. The policy limits of the Contractor's employer's liability insurance shall not be less than \$100,000 for "each accident," \$500,000 for "disease policy limit," and \$100,000 for "disease each employee." If the Contractor is self-insured, the Contractor shall provide proof of self-insurance and authorization to self-insure as required by applicable state laws and regulations.
- 14.7.3 Professional Liability Insurance. The Contractor shall purchase and maintain in force during the term of the Contract, Professional Liability insurance which will pay for damages arising out of errors or omissions in the rendering, or failure to render professional services under the Contract in the amount of at least ONE MILLION DOLLARS (\$1,000,000.00) per claim. Such insurance must contain nose and tail coverage to include work performed by the Contractor from the project's inception date and until such time as the Statue of Limitations has run for the work done on the project.
- 14.7.4 Deductibles. The Contractor's policies of insurance required by this Section 14.7 may require the Contractor's payment of a deductible, provided the Contractor's insurer is required to pay claims from the first dollar at 100% of the claim value without any requirement that the Contractor pay the deductible prior to its insurer's payment of the claim.
- 14.7.5 Other Insurance Requirements. All insurance policies required by this Section 14.7 shall provide that they are primary insurance with respect to any other valid insurance the City may possess, and that any other insurance the City does possess shall be considered excess insurance only. All such insurance shall be carried with a company or companies which meet the requirements of Section 15.2 of these General Conditions, and said policies shall be in a form satisfactory to the City. A properly completed and executed Certificate of Insurance on a form provided or approved by the City (such as a current ACORD certificate of insurance) evidencing the insurance coverage required by this Section shall be furnished to the City upon the Contractor's execution of the Contract. The Contractor shall provide the City with at least thirty (30) days' prior written notice of any adverse material change in the Contractor's required insurance coverage except that ten (10) days' notice of cancellation for non-payment is required. For purposes of this Section, an "adverse material change" shall mean any reduction in the limits of the insurer's liability, any reduction, non-renewal or cancellation of any insurance coverage, or any increase in the Contractor's self-insured retention. Prior to the expiration of any such policy, the Contractor shall file with the City a certificate of insurance showing that such insurance coverage has been renewed. If the insurance coverage is canceled or reduced, the Contractor shall, within five (5) days after such cancellation or reduction in coverage, file with the City a certificate showing that the required insurance has been reinstated or provided through another insurance company or companies approved by the City. If the Contractor fails to obtain or have such insurance reinstated, the City may, if it so elects, and without waiving any other remedy it may have against the Contractor, immediately terminate this Contract upon written notice to the Contractor. The City Manager shall have the right to alter the monetary limits or coverage herein specified from

time to time during the term of this Contract, and the Contractor shall comply with all reasonable requests of the City Manager with respect thereto.

15. SURETY BONDS/LETTERS OF CREDIT/LIABILITY INSURANCE

- 15.1 A surety Bond/Letter of Credit is not required for this Contract.
- 15.2 Liability Insurance Companies furnishing insurance coverage required by these General Conditions shall (a) be approved to issue insurance policies in the State of Georgia, and (b) must have no less than a "B+" Financial Rating and a Financial Size Category of "Class VI" or higher according to the most current edition of A.M. Best's Insurance Reports. If the liability insurer is rated by A.M. Best's Insurance Reports at an "A-" Financial Rating and a Financial Size Category of "Class VIII" or higher than the City Manager may waive the requirement for the insurer to be approved by the State of Georgia.

16. CONTRACT ADJUSTMENTS

- 16.1 Notwithstanding any provision herein to the contrary, the City reserves the right to modify at any time the nature, method, scope, frequency, or timing of the Contractor's obligations under this Contract (Contract Adjustments) in whatever manner it determines to be reasonably necessary for the proper completion of the Contractor's work hereunder. Both parties agree that, should any Contract Adjustments be made, the Contractor's compensation and the amount of the Performance Bond or Letter of Credit required, will be adjusted accordingly, in such amount or amounts as will be mutually agreed to by means of good faith negotiation by the City and the Contractor and, to the extent possible, by reference to any unit costs already established in the Proposal. Without exception, all deletions or additions to the scope of work will be set forth in a written Amendment to this Contract.
- 16.2 Notwithstanding the foregoing, the City shall have the right to terminate this Contract pursuant to the provisions of Section 18.2 herein should the Contractor and the City fail to reach agreement on the adjusted compensation, or the amount of the Performance Bond or Letter of Credit, within thirty (30) days after the date of the Contract Adjustment.
- 16.3 Notwithstanding the foregoing, there shall be no upward adjustment of the compensation on account of any Contract Adjustment made necessary or appropriate as a result of the mismanagement, improper act, or other failure of the Contractor, its employees, agents, or its subcontractors to properly perform its obligations and functions under this Contract.

17. SUBCONTRACTORS

- 17.1 The Contractor shall perform all of its obligations and functions under this Contract by means of its own employees, or by a duly qualified subcontractor which is approved in advance by the City. Such subcontractor which is an affiliate, parent, or subsidiary company; or had principal owners, relatives, management, or employees common to the Contractor; or any other party that has the ability to significantly influence the management or daily business operations of the subcontractor must be disclosed in writing to the City Manager. Goods and services provided by subcontractors which are reimbursed by the City must be bona fide arm's-lengths transactions. In the event a subcontractor is employed, the Contractor shall continuously monitor the subcontractor's performance, shall remain fully responsible to ensure that the subcontractor performs as required and itself perform or remedy any obligations or functions which the subcontractor fails to perform properly. Nothing contained herein shall be construed to prevent the Contractor from using the services of a common carrier for delivering goods to the City.
- 17.2 This Contract shall be referred to and incorporated within any contractual arrangement between the Contractor and a subcontractor and, in such contractual arrangement; the subcontractor shall give its express written consent to the provisions of this Section 17. To the extent feasible, the provisions of this Contract shall apply to any such subcontractor in the same manner as they apply to the Contractor. However, such application shall neither make any subcontractor a party to this Contract, nor make such subcontractor a third party beneficiary hereof.

- 17.3 In the event that the Contractor employs a subcontractor, then the City may require that copies of invoices for all work (including invoices submitted to the Contractor for work performed by a subcontractor) shall be submitted to the City by the Contractor and the City shall pay all compensation to the Contractor. It shall be the sole responsibility of the Contractor to deal with a subcontractor with respect to the collecting and submission of invoices and the payment of compensation. In no event shall the City have any obligation or liability hereunder to any subcontractor, including, in particular, any obligations of payment.

18. DEFAULT AND TERMINATION

- 18.1 In the event that:

- 18.1.1 the Contractor shall repeatedly fail (defined for this purpose as at least three (3) failures within any consecutive twelve (12) month period) to keep, perform or observe any of the promises, covenants or agreements set forth in this Contract (provided that notice of the first two (2) failures shall have been given to the Contractor, but whether or not the Contractor shall have remedied any such failure); or
- 18.1.2 the Contractor shall fail to keep, perform or observe any promise, covenant, or agreement set forth in this Contract, and such failure shall continue for a period of more than five (5) days after delivery to the Contractor of a written notice of such breach or default; or
- 18.1.3 the Contractor's occupational or business license shall terminate or the Contractor shall fail to provide the City with any bond, letter of credit, or evidence of insurance as required by the Contract Documents, for any reason; or
- 18.1.4 the Contractor fails for any reason to provide the City with an acceptable renewal or replacement bond or letter of credit within the time period specified by a provision of this Contract; or
- 18.1.5 the Contractor shall become insolvent, or shall take the benefit of any present or future insolvency statute, or shall make a general assignment for the benefit of creditors, or file a voluntary petition in bankruptcy or a petition or answer seeking an arrangement for its reorganization, or the readjustment of its indebtedness under the Federal Bankruptcy laws, or under any other law or statute of the United States or any State thereof, or shall consent to the appointment of a receiver, trustee or liquidator of all or substantially all of its property; or
- 18.1.6 the Contractor shall have a petition under any part of the Federal Bankruptcy laws, or an action under any present or future insolvency laws or statute filed against it, which petition is not dismissed within thirty (30) days after the filing thereof; or
- 18.1.7 There is any assignment by the Contractor of this Contract or any of the Contractor's rights and obligations hereunder for which the City has not consented in writing; or
- 18.1.8 The Contractor shall default on any other agreement entered into by and between Contractor and the City, then, in its discretion, the City shall have the right to terminate this Contract for default, which termination shall be effective upon delivery of written notice of such termination to the Contractor. In the event that the City terminates this Contract for default, or the Contractor abandons or wrongfully terminates the Contract, the Contractor shall be paid for compensation earned to the date of termination or abandonment (but the City shall have the right to reduce by off-set any amounts owed to the Contractor hereunder or under any other Contract or obligation by the amount of the City's damages and any amounts owed by the Contractor to the City), but the Contractor shall not be compensated for any profits earned or claimed after the receipt of the City's notice of termination by default or after abandonment or wrongful termination. The City's election to terminate or not to terminate this Contract in part or whole for the Contractor's default shall in no way be construed to limit the City's right to pursue and exercise any other right or

remedy available to it pursuant to the terms of the Contract or otherwise provided by law or equity.

- 18.2 Notwithstanding anything else herein contained, the City may terminate this Contract in whole or in part at any time for its convenience by giving the Contractor thirty (30) days written notice. In that event, the Contractor shall proceed to complete any part of the work, as directed by the City, and shall settle all its claims and obligations under the Contract, as directed by the City. The Contractor shall be compensated by the City in accordance with the provisions hereof, including in particular Section 2 of these General Conditions, provided, however, that in no event shall Contractor be entitled to compensation for work not performed or for anticipatory profits. Contractor shall justify its claims, as requested by the City, with accurate records and data.
- 18.3 Bankruptcy and Liquidation - In the event the Contractor (1) makes an assignment for the benefit of creditors, or petition or apply to any tribunal for the appointment of a custodian, receiver, or trustee for all or a substantial part of its assets; (2) commences any proceeding under any bankruptcy, reorganization, arrangement, readjustment of debt, dissolution, or liquidation law or statute of any jurisdiction whether now or hereafter in effect; (3) has had any such petition or application filed or any such proceeding commenced against it in which an order for relief is entered or an adjudication or appointment is made, and which remains un-dismissed for a period of sixty (60) days or more; (4) takes any corporate action indicating its consent to, approval of, or acquiescence in any such petition, application, proceeding, or order for relief or the appointment of a custodian, receiver, or trustee for all or substantial part of its assets; or (5) permits any such custodianship, receivership, or trusteeship to continue undischarged for a period of sixty (60) days or more causing the Contractor or any third party, including, without limitation, a trustee in bankruptcy, to be empowered under state or federal law to reject this Contract or any agreement supplementary hereto, the City shall have the following rights:
- (i) In the event of a rejection of this Contract or any agreement supplementary hereto, the City shall be permitted to retain and use any back-up or archival copies of the software licensed hereunder under this Agreement for the purpose of enabling it to mitigate damages caused to the City because of the rejection of this Contract. The City shall exert reasonable efforts to mitigate such damages by use of such back-up or archival copies.
 - (ii) In the event of rejection of this Contract or any agreement supplementary hereto, the City may elect to retain its rights under this Contract or any agreement supplementary hereto as provided in Section 365(n) of the Bankruptcy Code. Upon written request of the City to, as applicable, the Contractor or the bankruptcy trustee or receiver. The Contractor or such bankruptcy trustee or receiver shall not interfere with the rights of the City as licensee as provided in this Contract or in any agreement supplementary hereto to obtain the Source Material(s) from the bankruptcy trustee and shall, if requested, cause a copy of such Source Material(s) to be available to the City.
 - (iii) In the vent of rejection of this Contract or any agreement supplementary hereto, the City may elect to retain its rights under this Contract or any agreement supplementary hereto as provided in section 365(n) of the Bankruptcy Code without prejudice to any of its rights of setoff with respect to this Contract under the Bankruptcy Code or applicable non-bankruptcy law; or In the event of a rejection of this Contract or any agreement supplementary hereto, the City may retain its rights under this Contract or any agreement supplementary hereto as provided in section 365(n) of the Bankruptcy Code without prejudice to any of its rights under section 503(b) of the Bankruptcy Code.

19. CITY'S AUTHORIZED REPRESENTATIVE

During the term of this Contract, the City Manager or designee may from time to time designate an individual to serve as the City's Authorized Representative and an Assistant Representative designated to serve in that capacity in the absence of the CITY'S AUTHORIZED REPRESENTATIVE, who shall have such authority to act on the City's behalf as the City Manager may from time to time actually delegate to such person, but in no event shall the CITY'S AUTHORIZED REPRESENTATIVE have authority to modify or terminate this Contract, or make final decisions with respect to amendments, time extensions, assignments, cost or payment adjustments or payment disputes.

20. ASSIGNMENT

Neither this Contract nor any of the Contractor's rights or obligations hereunder may be assigned by the Contractor without the City's prior written consent, which consent may be granted or withheld at the City's sole discretion. Any transfer of this Contract by merger, consolidation or liquidation (unless the stock of the Contractor is traded on a national stock exchange or in a generally recognized over the counter securities market) any change in ownership of or power to vote a majority of the outstanding voting stock or ownership interests of the Contractor shall constitute an assignment of this Contract for purposes of this Section. In the event the Contractor assigns or subcontracts or attempts to assign or subcontract any right or obligation arising under this Contract without the City's prior written consent, the City shall be entitled to terminate this Contract pursuant to the provisions of Section 17 hereof.

21. NOTICES

21.1 Unless otherwise stated herein, all notices or other writings which the City is required or permitted to give to the Contractor may be hand delivered, mailed via U.S. Certified Mail or sent next-day delivery by a nationally-recognized overnight delivery service to the Contractor's address set forth in the Proposal. Any such notice shall be deemed to have been delivered upon actual delivery, or one (1) day following submission to a nationally-recognized overnight delivery service for next day delivery to the Contractor, or three (3) days following submission to the Contractor by U.S. Certified Mail.

21.2 Unless otherwise stated herein, all notices or other writings which the Contractor is required or permitted to give to the City may be hand delivered to the City Manager, mailed via U.S. Certified Mail, or sent next-day delivery by a nationally-recognized overnight delivery service. Any such notice shall be deemed to have been delivered upon actual delivery, or one (1) day following submission to a nationally-recognized overnight delivery service for next day delivery to City, or three (3) days following submission to the City by U.S. Certified Mail. Any such notice shall be sent to:

City of Dunwoody, GA
ATTN: City Manager
Dunwoody City Hall Building, 4800 Ashford Dunwoody Road
Dunwoody, GA 30338

21.3 Either party may change its notice address by written notice to the other given as provided in this section.

22. NONDISCRIMINATION

22.1 During the performance of this Contract, the Contractor, for itself, its assignees and successors in interest agrees as follows:

22.1.1 Compliance with Regulations. The Contractor shall comply with the Laws and Regulations as they may be amended from time to time (hereafter referred to as the "Regulations"), which are herein incorporated by reference and made a part of this Contract.

22.1.2 Nondiscrimination. The Contractor, with regard to the work performed by it during the Contract, shall not discriminate on the grounds of race, color, or national origin in the selection and retention of any subcontractor, including procurement of materials and leases of equipment. The Contractor shall not participate either directly or indirectly in the discrimination prohibited by the Regulations.

22.1.3 Solicitations for Subcontracts, Including Procurement of Materials and Equipment. In all solicitations either by competitive proposing or negotiation made by the Contractor for work to be performed under a subcontract, including procurement of materials or leases of equipment, each potential subcontractor or supplier shall be notified by the Contractor of the Contractor's obligations under this Contract and the Regulations relative to nondiscrimination on the grounds of race, color or national origin.

22.1.4 Information and Reports. The Contractor shall provide all information and reports required by the Regulations or directives issued pursuant thereto and shall permit access to its books, records,

accounts, other sources or information, and its facilities as may be determined by the City to be pertinent to ascertain compliance with such Regulations, orders and instructions. Where any information required of the Contractor is in the exclusive possession of another who fails or refuses to furnish this information, the Contractor shall so certify to the City, as appropriate, and shall set forth what efforts it has made to obtain the information.

22.1.5 Sanctions for Noncompliance. In the event of the Contractor's noncompliance with the nondiscrimination provisions of this Contract, the City shall impose such Contract Sanctions as it may determine to be appropriate, including but not limited to:

22.1.5.1 Withholding of payments to the Contractor under the Contract until the Contractor complies, and/or

22.1.5.2 Cancellation, termination or suspension of the Contract, in whole or in part.

22.1.6 Incorporation of Provisions. The Contractor shall include the provisions of subsections 22.1.1 through 22.1.5 in every subcontract, including procurement of materials and leases of equipment, unless exempt by the Regulations or directives issued pursuant thereto. The Contractor shall take such action with respect to any subcontract or procurement as the City may direct as a means of enforcing such provisions including sanctions for noncompliance. Provided, however, that in the event the Contractor becomes involved in, or is threatened with, litigation with a subcontractor or supplier as a result of such direction, the Contractor may request the City to enter into such litigation to protect the interest of the City and, in addition, the Contractor may request the United States to enter into such litigation to protect the interests of the United States.

22.2 The Contractor assures the City that it will comply with the pertinent statutes, Executive Orders and such rules as are promulgated to assure that no person shall, on the grounds of race, creed, color, national origin, sex, age, marital status, or handicap be excluded from participating in any activity conducted with or benefiting from Federal assistance. This provision shall bind the Contractor from the period beginning with the initial solicitation through the completion of the Contract.

23. **COPYING DOCUMENTS**

The Contractor hereby grants the City and its agent's permission to copy and distribute any and all materials and documents contained in, comprising, or which are otherwise submitted to the City with or in connection with the Contractor's Proposal or which are contained in the Contract Documents (the "Submittals"). The permission granted by the Contractor shall be on behalf of the Contractor and any and all other parties who claim any rights to any of the materials or documents comprising the Submittals. Such permission specifically authorizes the City and its agents to make and distribute such copies of the Submittals or portions thereof as may be deemed necessary or appropriate by the City for its own internal purposes or for responding to requests for copies from any member of the public regardless of whether the request is specifically characterized as a public records request pursuant to Georgia Code. This provision shall survive the expiration or termination of the Contract.

24. **GENERAL PROVISIONS**

24.1 The Contract Documents consist of the Contract, the Proposal Forms, the Instructions to Proposers, Request for Proposals, all Addendum(s) issued prior to execution of this Contract, these General Conditions and the Specifications. Together, these documents comprise the Contract and all the documents are fully a part of the Contract as if attached to the Contract or repeated therein. Precedence of the Contract Documents shall be as follows: (i) addendum(s) to the Contract Documents, (ii) the Contract, (iii) the General Conditions (iv) the Proposal Forms, (v) the Instructions to Proposers, (vi) the Specifications, and (vii) the Request.

24.2 This Contract represents the entire agreement between the parties in relation to the subject matter hereof and supersedes all prior agreements and understandings between such parties relating to such subject matter, and there are no contemporaneous written or oral agreements, terms or representations made by any party other than those contained herein. No verbal or written representations shall be relied upon outside the Contract terms and

amendments. Without exception, all deletions or additions to the scope of work will be set forth in a written amendment to this Contract. No amendment, modification, or waiver of this Contract, or any part thereof, shall be valid or effective unless in writing signed by the party or parties sought to be bound or charged therewith; and no waiver of any breach or condition of this Contract shall be deemed to be a waiver of any other subsequent breach or condition, whether of a like or different nature.

- 24.3 The Contractor shall, during the term of this Contract, repair any damage caused to real or personal property of the City and/or its tenants, wherever situated, caused by the intentional, reckless, or negligent acts or omissions of the Contractor's officers, agents, or employees, and any subcontractors and their officers, agents, or employees, or, at the option of the City, the Contractor shall reimburse the City for the cost of repairs thereto and replacement thereof accomplished by or on behalf of the City.
- 24.4 The Contractor warrants to the City that no work performed or materials purchased pursuant to the Contract, whether by, from, or through the Contractor or a subcontractor, shall cause any claim, lien or encumbrance to be made against any property of the City, and the Contractor shall indemnify and save the City harmless from and against any and all losses, damages and costs, including attorneys' fees, with respect thereto. If any such claim, lien or encumbrance shall be filed, the Contractor shall, within thirty (30) days after notice of the filing thereof, cause the same to be discharged of record by payment, deposit, bond, order of a court of competent jurisdiction or otherwise. This provision shall survive the expiration or termination of the Contract.
- 24.5 The language of this Contract shall be construed according to its fair meaning, and not strictly for or against either the City or the Contractor. This Contract shall be deemed to be made, construed and performed according to the laws of the State of Georgia. Any suit or proceeding initiated for the purpose of interpreting or enforcing any provision of this Contract or any matter in connection therewith shall be brought exclusively in a court of competent jurisdiction in DeKalb County, Georgia, and the Contractor waives any venue objection, including, but not limited to, any objection that a suit has been brought in an inconvenient forum. The Contractor agrees to submit to the jurisdiction of the Georgia courts and irrevocably agrees to acknowledge service of process when requested by the City
- 24.6 The section headings herein are for the convenience of the City and the Contractor, and are not to be used to construe the intent of this Contract or any part hereof, or to modify, amplify, or aid in the interpretation or construction of any of the provisions hereof.
- 24.7 The use of any gender herein shall include all genders, and the use of any number shall be construed as the singular or the plural, all as the context may require.
- 24.8 The delay or failure of the City at any time to insist upon a strict performance of any of the terms, conditions and covenants herein shall not be deemed a waiver of that breach or any subsequent breach or default in the terms, conditions, or covenants of this Contract. The Contractor shall not be relieved of any obligation hereunder on account of its failure to perform by reason of any strike, lockout, or other labor disturbance.
- 24.9 If the City shall, without any fault, be made a party to any litigation commenced between the Contractor and a third party arising out of the Contractor's operations and activities at the premises, then the Contractor shall pay all costs and reasonable attorney's fees incurred by or imposed upon the City in connection with such litigation for all trial and appellate proceedings. The City shall give prompt notice to the Contractor of any claim or suit instituted against it by such third party. The provisions of this Section supplement and are not intended to be in lieu of the indemnification provisions of Section 5 hereof. The provisions of this Section shall survive the acceptance of the services and payment therefore, and the expiration or earlier termination of this Contract.
- 24.10 The City shall have the right to recover from the Contractor all of the City's costs and expenses incurred in enforcing the provisions of this Contract including, but not limited to, (1) the cost of administrative investigation and enforcement (including, without limitation, audit fees and costs, attorneys' fees) and (2) the cost of any trial, appellate or bankruptcy proceeding (including, without limitation, investigation costs, audit

fees and costs, attorneys' fees, court costs, paralegal fees and expert witness fees). This provision shall survive the expiration or termination of the Contract.

- 24.11 The Contractor shall not during the term of the Contract knowingly hire or employ (on either a full-time or part-time basis) any employee of the City.
- 24.12 The Contractor shall be required, during the term of the Contract, at no additional cost to the City, to take such reasonable security precautions with respect to its operations at City Hall as the City in its discretion may from time to time prescribe. The Contractor shall comply with all regulations, rules and policies of any governmental authority, including the City, relating to security issues.
- 24.13 The City may, but shall not be obligated to, cure, at any time, upon five (5) days written notice to the Contractor (provided, however, that in any emergency situation the City shall be required to give only such notice as is reasonable in light of all the circumstances), any default by the Contractor under this Contract; whenever the City so cures a default by the Contractor, all costs and expenses incurred by the City in curing the default, including, but not limited to, reasonable attorneys' fees, shall be paid by the Contractor to the City on demand.
- 24.14 The City shall, in its discretion, be entitled to deduct from the compensation to which the Contractor is otherwise entitled hereunder, an amount equal to any liabilities of the Contractor to the City which are then outstanding. In the event that additional work beyond the scope of this Contract is requested by the City Manager and it results in any extra charges to the City, the Contractor shall so advise the City in writing of the amount of the extra charges. The City is not required to pay any extra charges for additional work unless such work and the charges therefore have been approved in advance and have been confirmed in writing within twenty-four (24) hours by the City Manager, in his or her exclusive discretion.
- 24.15 The Contractor is an independent contractor and nothing contained herein shall be construed as making the Contractor an employee, agent, partner or legal representative of the City for any purpose whatsoever. The Contractor acknowledges that it does not have any authority to incur any obligations or responsibilities on behalf of the City, and agrees not to hold itself out as having any such authority. Nothing contained in this Contract shall be construed to create a joint employer relationship between the City and the Contractor with respect to any employee of the Contractor or of its subcontractors.
- 24.16 The Contractor and its subcontractors, if any, shall maintain complete and accurate books and records in accordance with generally accepted accounting principles, consistently applied, and shall be in a form reasonably acceptable to the City Manager or designee. The Contractor and its subcontractors shall account for all expenses of any nature related to transactions in connection with this Contract in a manner which segregates in detail those transactions from other transactions of the Contractor and subcontractors and which support the amounts reported and/or invoiced to the City. At a minimum, the Contractor's and subcontractor's accounting for such expenses and transactions shall include such records in the form of electronic media compatible with or convertible to a format compatible with computers utilized by the City at its offices; a computer run hard copy; or legible microfilm or microfiche, together with access to the applicable reader. All such books and records and computerized accounting systems, shall upon reasonable notice from the City be made available in DeKalb County, Georgia, for inspection, examination, audit and copying by the City through and by its duly authorized representatives at any time for up to four (4) years after the year to which books and records pertain. Such inspection, examination, or audit may include, but is not limited to a review of the general input, processing, and output controls of information systems, using read only access, for all computerized applications used to record financial transactions and information. The Contractor and subcontractor shall freely lend its own assistance in a timely manner in making such inspection, examination, audit, or copying and, if such records are maintained in electronic and other machine readable format, shall provide the City and/or its representative such assistance as may be required to allow complete access to such records. The City Manager may require the Contractor and subcontractors to provide other records the City Manager, in his or her sole discretion, deems necessary to enable the City to perform an accurate inspection, examination or audit of expenses incurred in and transactions related to performance of this Contract. Such records shall be provided within thirty (30) days of request thereof. In the event that expenses incurred or reimbursed are found by such inspection, examination, or

audit to have been overpaid, the Contractor and its subcontractors agree that such amounts shall be payable to the City. If, prior to the expiration of the above-stated four (4) year record retention period, any audit or investigation is commenced by the City, or any claim is made or litigation commenced relating to this Contract by the City, the Contractor, or a third party, the Contractor shall continue to maintain all such records, and the City shall continue to have the right to inspect such records in the manner stated above, until the inspection, examination, audit, claim, or litigation is finally resolved (including the determination of any and all appeals or the expiration of time for an appeal). This provision shall survive the expiration or earlier termination of this Contract. In the event of any conflict between any provision of this Contract and generally accepted accounting principles or generally accepted auditing standards, the provisions of this Contract shall control even where this Contract references such provisions or standards. In particular, without limitation, the Contractor and subcontractors shall maintain all records required under this Contract to the full extent required hereunder, even if some or all such records would not be required under such generally accepted accounting principles or auditing standards. If as a result of an inspection, examination or audit, it is established that amounts are due from the Contractor to the City, the Contractor shall forthwith, upon written demand from the City, pay the City such amount, together with interest on the amount due at the rate of eighteen (18%) percent per annum, or if less, the maximum rate of interest allowed by law, from the date such additional amounts were overpaid by the City. Further if such inspection, examination or audit establishes that the Contractor has over billed such amounts for any Contract period by two (2%) percent or more, then the entire expense of such inspection, examination or audit shall be paid by the Contractor.

- 24.17 The Contractor and subcontractors shall prepare and provide the City with all detailed reports as required under the Contract on a timely basis. The City reserves the right to modify the reporting procedures or the form and content of any report as it deems necessary.
- 24.18 There are no third party beneficiaries to this Contract and nothing contained herein shall be construed to create such.
- 24.19 Time is of the essence for the performance of each of the Contractor's obligations under this Contract.
- 24.20 In computing any period of time established under this Contract, except as otherwise specified herein the word "days," when referring to a period of time that is ten (10) days or less means business days, and when referring to a period of time that is more than ten (10) days means calendar days. The day of the event, from which the designated period of time begins to run shall not be included. A business day is any day other than Saturday, Sunday, or Federal, State of Georgia or City holidays.
- 24.21 The Contractor agrees to perform all acts and execute all supplementary instruments or documents which may be reasonably necessary to carry out or complete the transaction(s) contemplated by this Contract.
- 24.22 The City reserves the right to further develop, improve, repair and alter the facilities and all roadways, and parking areas, as it may reasonably see fit, free from any and all liability to the Contractor for loss of business or damages of any nature whatsoever to the Contractor occasioned during the making of such improvements, repairs, alterations and additions, including, but not limited to, any damages resulting from negligence of the City or its employees, agents or contractors.
- 24.23 The Contractor and the City hereby mutually waive any claim against each other and their respective members, officials, officers, agents and employees for damages (including damages for loss of anticipated profits) caused by any suit or proceedings brought by either of them or by any third party directly or indirectly attacking the validity of this Contract or any part thereof, or any addendum or amendment hereto, or the manner in which this Contract was solicited, awarded or negotiated, or arising out of any judgment or award in any suit or proceeding declaring this Contract, or any addendum or amendment hereto, null, void or voidable or delaying the same, or any part thereof, from being carried out.
- 24.24 At the option of the Contractor, the products and/or services provided under the Contract resulting from this solicitation may be provided to other governmental agencies, including the State of Georgia, its agencies,



4800 Ashford Dunwoody Road
Dunwoody, Georgia 30338
dunwoodyga.gov | 678.382.6700

political subdivisions, counties and cities under the same terms and conditions, including price, as such products and/or services are provided under this Contract. Each governmental agency allowed by the Contractor to purchase products and/or services in connection with this Contract shall do so independent of the City or any other governmental entity. Each agency shall be responsible for its own purchases and shall be liable only for goods and services ordered, received and accepted by it. The City shall have no liability to the Contractor or any governmental agency resulting from the purchase by that agency of products and/or services from the Contractor in connection with this Contract.

24.25 Contractor must adhere to the City's Travel Policy.

* * * * * END OF GENERAL CONDITIONS * * * * *